

Gasmonitor +

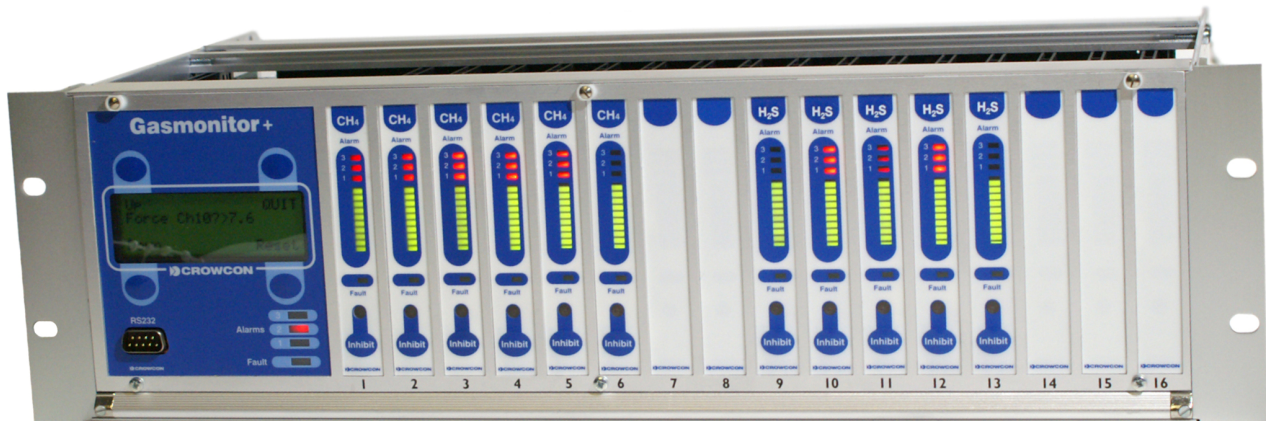

Installation, Operation and Maintenance Manual

M07210
Issue 7
January 2009

 **CROWCON**
Gas Detection You Can Trust

Notes:

The equipment described in this manual may have mains voltages applied to it. Ensure correct safety procedures are adopted before working on the equipment.

The equipment described in this manual is designed for the detection of flammable and/or toxic gases. Detectors may be sited in hazardous areas. Ensure local safety procedures are adopted before carrying out any maintenance or calibration work.

The equipment described in this manual may be connected to remote alarms and/or shutdown systems. Ensure that local operating procedures are adopted before carrying out any maintenance or calibration work.



This product has been tested and found to comply with the European Directive 89/336/EEC and the EMC requirements of EN50270.

CONTENTS

1 INTRODUCTION	1
1.1 General	1
1.2 System Overview	1
1.2.1 What is Gasmonitor+?	1
1.2.2 What are the Main Components?	2
1.2.3 Specification Sheet (Sample Only)	4
2 HARDWARE	2
2.1 19" Control Rack	2
2.1.1 Description	2
2.1.2 Mounting Detail	4
2.1.3 Electrical Connections	5
2.1.4 Jumper Settings	5
2.2 Display Module	7
2.2.1 Description	7
2.2.2 Routine Operation	8
2.2.2.1 Common Alarm Relay and LED Operation	8
2.2.2.2 Dedicated Audible and Visual Alarm Drive Operation	10
2.2.2.3 Voted Relay Operation	10
2.2.2.4 Fault Messages	11
2.2.3 Mounting Detail	12
2.2.4 Electrical Connections	13
2.3 Universal Gas Input Card	14

2.3.1 Description	14
2.3.2 Routine Operation	15
2.3.2.1 LED Indicators	15
2.3.2.2 Channel Inhibit	16
2.3.2.3 Individual Channel Alarm Relays	16
2.3.2.4 Repeated Analogue Output	17
2.3.3 Mounting Detail	17
2.3.4 Electrical Connections	18
2.3.5 Jumper Settings	19
2.4 Twin Zone Fire Input Card	21
2.4.1 Description	21
2.4.2 Routine Operation	22
2.4.2.1 LED Indicators	22
2.4.2.2 Channel Inhibit	22
2.4.2.3 Individual Channel and Zone Alarm Relays	23
2.4.3 Mounting Detail	23
2.4.4 Electrical Connections	24
2.4.5 Jumper Settings	25
2.5 Input/Output Module	26
2.5.1 Description	26
2.5.2 Mounting Detail	28
2.5.3 Electrical Connections	28
2.6 Relay Module	31
2.6.1 Description	31
2.6.2 Mounting Detail	32
2.6.3 Electrical Connections (General)	33
2.6.3.1 Electrical Connections (Individual Channel Alarms – Gas Only)	34
2.6.3.2 Electrical Connections (Individual Channel Alarms – Fire Only)	35
2.6.3.3 Electrical Connections (Voted Relays)	36
2.7 Power Distribution	37
2.7.1 Description	37
2.7.2 Routine Operation	38
2.7.3 Mounting Detail	39
2.7.3.1 Power Module	39
2.7.3.2 Power Supply Unit	41
2.7.3.3 Batteries	43
2.7.4 Electrical Connections	44

2.7.5 Calculation of Power Supply Requirements and Battery Backup	45
2.7.5.1 Typical Power Consumption of Gasmonitor+ Modules	45
2.7.5.2 Example Power/Battery Backup Calculation	46
Step 1 : Calculate maximum current consumption of the system	46
Step 2 : Size the Power Supply Unit	46
Step 3 : Calculate the battery backup time	47
3 FIELD DEVICES	48
3.1 General	48
3.2 Gas Detector Installation and Operation	49
3.2.1 Approved Gas Detectors	49
3.2.2 Detector Location	51
3.2.3 Set-up and Operation: 3 wire mV bridge devices	52
3.2.3.1 General	52
3.2.3.2 Cabling Requirement	52
3.2.4 Earthing	53
3.2.5 Universal Gas Input Card Jumper Settings	53
3.2.6 Electrical Connections	54
3.2.7 Setting to Work	56
3.2.7.1 Calibration	57
3.2.7.2 Routine Functional Testing	58
3.2.8 Set-up and Operation: 3 wire 4-20 mA devices	60
3.2.8.1 General	60
3.2.8.2 Cabling Requirement	60
3.2.8.3 Earthing	61
3.2.8.4 Universal Gas Input Card Jumper Settings	61
3.2.8.5 Electrical Connections	62
3.2.8.6 Setting to Work	63
3.2.8.7 Calibration	63
3.2.8.8 Routine Functional Testing	64
3.2.9 Set-up and Operation: 2 wire 4-20 mA intrinsically safe devices	66
3.2.9.1 General	66
3.2.9.2 Cabling Requirement	66
3.2.9.3 Earthing	67
3.2.9.4 Universal Gas Input Card Jumper Settings	68

3.2.9.5 Electrical Connections	69
3.2.9.6 Setting to Work	73
3.2.9.7 Calibration	73
3.2.9.8 Routine Functional Testing	74
3.2.10 Set-up and Operation: 2 wire 4-20 mA flameproof devices	76
3.2.10.1 General	76
3.2.10.2 Cabling Requirement	76
3.2.10.3 Earthing	76
3.2.10.4 Universal Gas Input Card Jumper Settings	77
3.2.10.5 Setting to Work	77
3.2.10.6 Calibration	77
3.2.10.7 Routine Functional Testing	79
3.3 Fire Detector Installation and Operation	81
3.3.1 Approved Detectors	81
3.3.2 Detector Location	82
3.3.3 Set-up Procedure: Generic to all Fire Detectors and Manual Alarm Call Points	83
3.3.3.1 Cabling Requirement	83
3.3.3.2 Earthing	83
3.3.3.3 Twin Zone Fire Input Card Jumper Settings	84
3.3.3.4 Electrical Connections	84
3.3.3.5 Routine Functional Testing	84
3.3.3.6 Dummy Loads	87
3.4 Audible/Visual Alarm Installation	89
3.4.1 Dedicated Drives for Audible/Visual Alarms	89
3.4.1.1 Cabling Requirement	89
3.4.1.2 Earthing	91
3.4.1.3 Electrical Connections	91
 APPENDIX A DISPLAY MODULE MENU OPERATION	 95
 APPENDIX B WINDOWS BASED SOFTWARE FOR THE PC	 105
 Contents	 105

APPENDIX C	127
SPARE PARTS LIST	127
WARRANTY	129

CONTENTS

LIST OF ILLUSTRATIONS

Figure	Page No.
Figure 1: Gasmonitor+ Block System Schematic	3
Figure 2: Specification Sheet Example	5
Figure 3: Gasmonitor+ General Isometric View	3
Figure 4: 19" Control Rack Mounting Detail (mm)	4
Figure 5: 19" Control Rack Electrical Connections, Front/Rear View	6
Figure 6: Display Module General View	7
Figure 7: Display Module Mounting Detail	12
Figure 8: Display Module Electrical Connections	13
Figure 9: Universal Gas Input Card General View	14
Figure 10: Universal Gas Input Card Mounting Detail	18
Figure 11: Universal Gas Input Card Jumper Locations	20
Figure 12: Twin Zone Fire Input Card General View	21
Figure 13: Twin Zone Fire Input Card Mounting Detail	24
Figure 14: Twin Zone Fire Input Card Jumper Locations	25
Figure 15: Input/Output Module General View	27
Figure 16: Input/Output Module Mounting Detail (mm)	28
Figure 17: Input/Output Module Terminal Detail	29
Figure 18: Relay Module General View	31
Figure 19: Relay Module Mounting Detail (mm)	32
Figure 20: Relay Module Terminal Detail	33
Figure 21: Relay Module Electrical Connections	34
Figure 22: Relay Module Electrical Connections	35
Figure 23: Relay Module Electrical Connections (Voted Relays)	36
Figure 24: Power Module General Arrangement	39
Figure 25: Power Module Mounting Detail	40

Figure 26 (a): 300W Power Supply Mounting Detail (mm)42

Figure 26 (b): 150W Power Supply Mounting Detail (mm)42

Figure 27: Battery Dimensions (mm)43

Figure 28: Power Distribution/Electrical Connections44

Figure 29: Gasmonitor+ 3-wire mV bridge type gas detectors55

Figure 30: Gasmonitor+ to 3-wire 4-20 mA type detectors62

Figure 31 (a): Gasmonitor+ to 2-wire type current sink (loop powered) detector69

Figure 31 (b): Gasmonitor+ to 2-wire I.S. type detector via Zener Barrier Typical Wiring Detail70

Figure 31 (c): Gasmonitor+ to 2-wire I.S. type detector via MTL 3041 Galvanic Isolator Typical Wiring Detail71

Figure 31 (d): Gasmonitor+ to 2-wire I.S. type detector MTL 5041 Galvanic Isolator Typical Wiring Detail72

Figure 32: Fire Detection Circuit Schematic Representation81

Figure 33 (a): Gasmonitor+ to Series 65 Fire Detectors Wiring Detail (Safe Area Only)85

Figure 33 (b): Gasmonitor+ to Series 65 Fire Detectors Wiring Detail (Hazardous Area)86

Figure 34 (a): Pellistor 3-wire mV Bridge87

Figure 34 (b): 4-20mA Current Sink – Toxics87

Figure 34 (c): 4-20mA Current Sink – Oxygen88

Figure 34 (d): Fire Channels88

Figure 35: Dedicated Audible/Visual Alarm Drives90

Figure 36 (a): Audible/Visual Alarms Typical Wiring Detail (Safe Area Only)92

Figure 36 (b): Audible/Visual Alarms Typical Wiring Detail (Hazardous Area)93

Figure 37: Gasmonitor+ Exploded View128

1 INTRODUCTION

1.1 General

This manual describes the installation, configuration and operation of a Gasmonitor+ gas and fire detection system with serial number 0568GM or higher.

Systems with serial numbers lower than this may not include all the features described in this manual.

A Gasmonitor+ gas and fire control system is normally fitted into a wall mounted or floor standing control cabinet. The physical arrangement depends on the size and complexity of the system, which is beyond the scope of this manual.

This manual details the operation of Gasmonitor+ with a range of field devices available from Crowcon. Other devices may be used as advised by Crowcon.

For further details please contact Crowcon's Service Department.

1.2 System Overview

1.2.1 What is Gasmonitor+?

Gasmonitor+ is a 19" rack mounted gas and fire control system. It is designed to control remote gas and fire detectors and raise audible/visual alarms should pre-set alarm levels be exceeded.

Gasmonitor+ can accommodate a mix of up to 16 gas or fire input cards per 19" control rack. Each gas input card may be configured to control one flammable or one toxic/oxygen gas detector. Each fire input card can control two independent loops of up to 20 conventional fire detectors including smoke, heat and manual alarm call points.

The alarm status of the remote detectors is displayed on the front panel of the associated input card via LEDs. Actual readings of the gas concentration at each gas detector are displayed on a common Display Module mounted on the left in each control rack.

Common alarm output relays are provided as standard. Individual channel alarms may be provided via dedicated relays mounted on optional Relay Modules.

Gasmonitor+ is microprocessor driven and may be controlled and configured via the push buttons mounted on the front of the Display Module. Alternatively, it may be configured using the Windows based SetGmon software provided.

Gasmonitor+ also includes a built in data logger as standard. Data may be retrieved using the Windows based LogManager software provided.

1.2.2 What are the Main Components?

The main components of a Gasmonitor+ gas and fire control system are:

- 19" Control Rack
- Power Module/Power Supply Unit/Battery Backup
- Display Module
- Universal Gas Input Card
- Twin Zone Fire Card
- Input/Output Module
- Relay Module
- Flammable Gas Detectors
- Toxic Gas Detectors
- Fire Detectors

These are shown schematically in Figure 1.

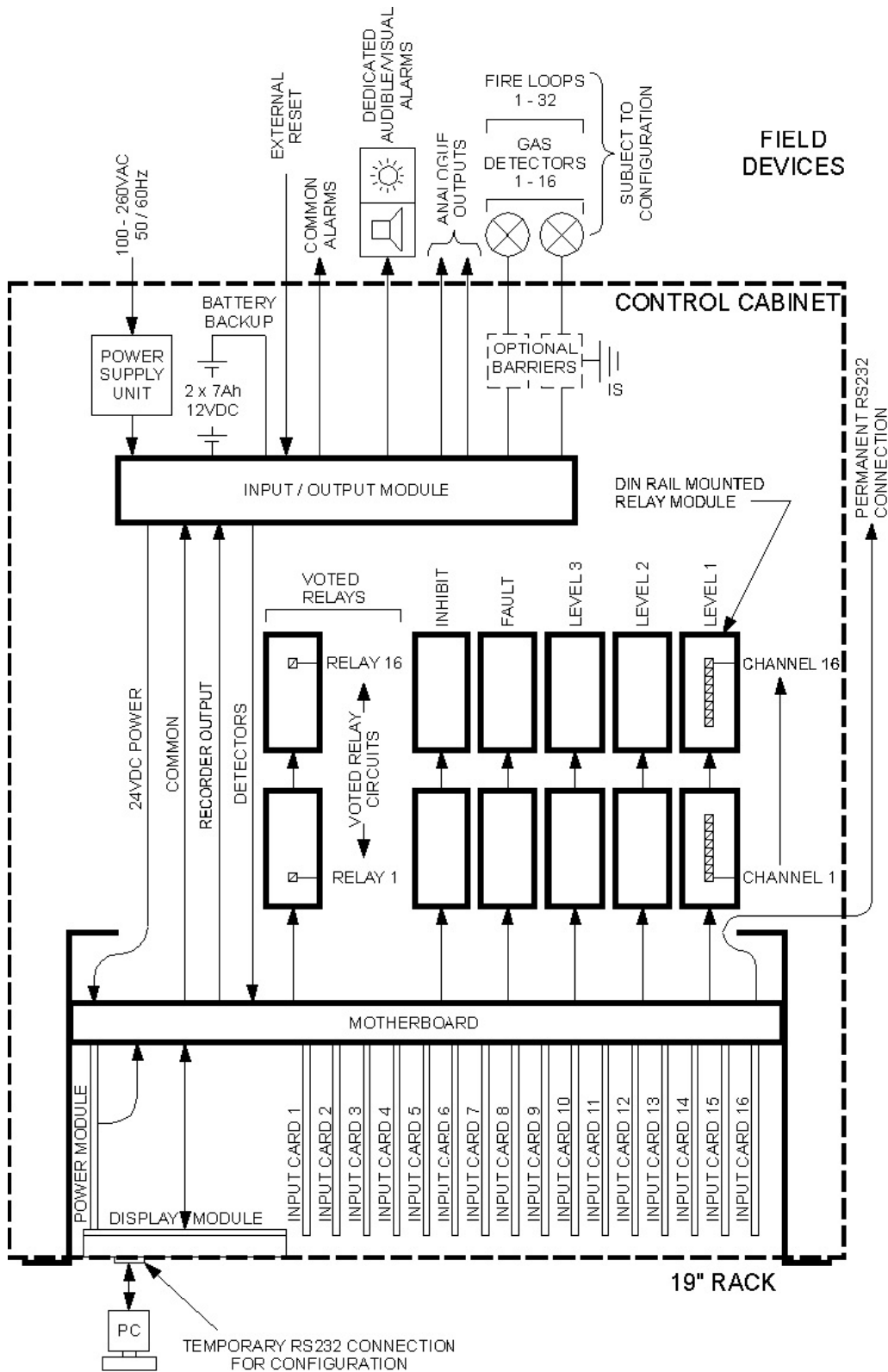

Figure 1: Gasmonitor+ Block System Schematic

1.2.3 Specification Sheet (Sample Only)

The system configuration is summarised on the Specification Sheet provided with each control panel. See below for an example.

HALMA GROUP
ESTD 1976/80

SYSTEM SPECIFICATION

GASMONITOR SYSTEM

Please find attached a copy of the Specification for the equipment to be supplied against your above order.

Please check and advise if any part of the Specification is not as you require.

HALMA GROUP COMPANY

GASMONITOR SPECIFICATION, CALIBRATION, INSPECTION AND TEST CERTIFICATE

CUSTOMER: **ORDER NO:**

ADDRESS: **CONTACT NAME:**

DATE FOR: **DATE:**

WORKS ORDER NO: **QUANTITY:**

DESCRIPTION: **INSPECTION DATE:**

NO.	DESCRIPTION	UNIT	VALUE	TESTED	RESULT
1					
2					
3					
4					
5					
6					
7					
8					
9					
10					
11					
12					
13					
14					
15					
16					
17					
18					
19					
20					

TESTED BY: **DATE:**

APPROVED BY: **DATE:**

INTRODUCTION

CROWCON

GASMONITOR, SPECIFICATION, CALIBRATION, INSPECTION AND TEST CERTIFICATE

ORDER NO: **DATE:**

ADDRESS: **CONTACT NAME:**

NO.	DESCRIPTION	UNIT	VALUE	TESTED	RESULT
1					
2					
3					
4					
5					
6					
7					
8					
9					
10					
11					
12					
13					
14					
15					
16					
17					
18					
19					
20					

TESTED BY: **DATE:**

APPROVED BY: **DATE:**

CROWCON

GASMONITOR SPECIFICATION, CALIBRATION, INSPECTION AND TEST CERTIFICATE

ORDER NO: **DATE:**

ADDRESS: **CONTACT NAME:**

NO.	DESCRIPTION	UNIT	VALUE	TESTED	RESULT
1					
2					
3					
4					
5					
6					
7					
8					
9					
10					
11					
12					
13					
14					
15					
16					
17					
18					
19					
20					

TESTED BY: **DATE:**

APPROVED BY: **DATE:**

Figure 2: Specification Sheet Example

2 HARDWARE

2.1 19" Control Rack

2.1.1 Description

All Gasmonitor+ control cards are mounted in a 3U high, 19" rack. The rack includes a drop down front panel, card guides and motherboard into which the control cards are fitted. The drop down panel is held in place by three locking screws located at the top of the panel.

Self adhesive labels are fitted to the front of the drop down panel detailing the control card mounted behind that particular label. The labels are fitted with pushbuttons that are wired to the control card in that position via a flexible connector.

A motherboard is fitted to the rear of the rack. The motherboard provides necessary power distribution, internal data transfer and routing of electrical signals to remote detectors and alarms via Input/Output Module and optional Relay Modules.

The drop down front panel and motherboard are electrically bonded to the chassis. This ensures that EMC/RFI regulations are met.

The Display Module is always fitted to the left of the control rack. Subsequent slots are filled with either the Universal Gas Input Card or Twin Zone Fire Input Card as required by the application.

Figure 3 gives a general view of the control rack.

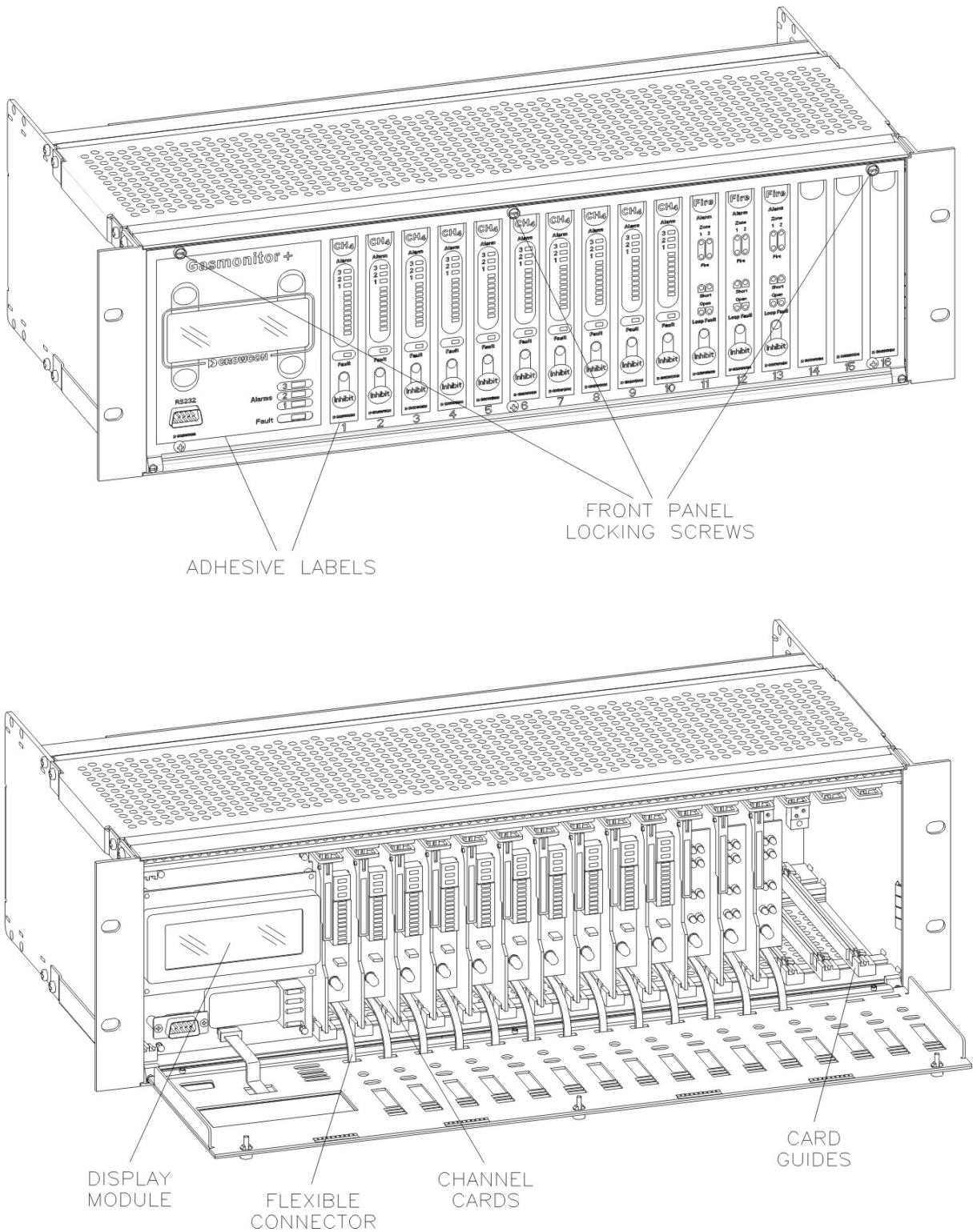

HARDWARE

Figure 3: Gasmonitor+ General Isometric View

2.1.2 Mounting Detail

Figure 4 below details the mounting arrangement of the control rack.

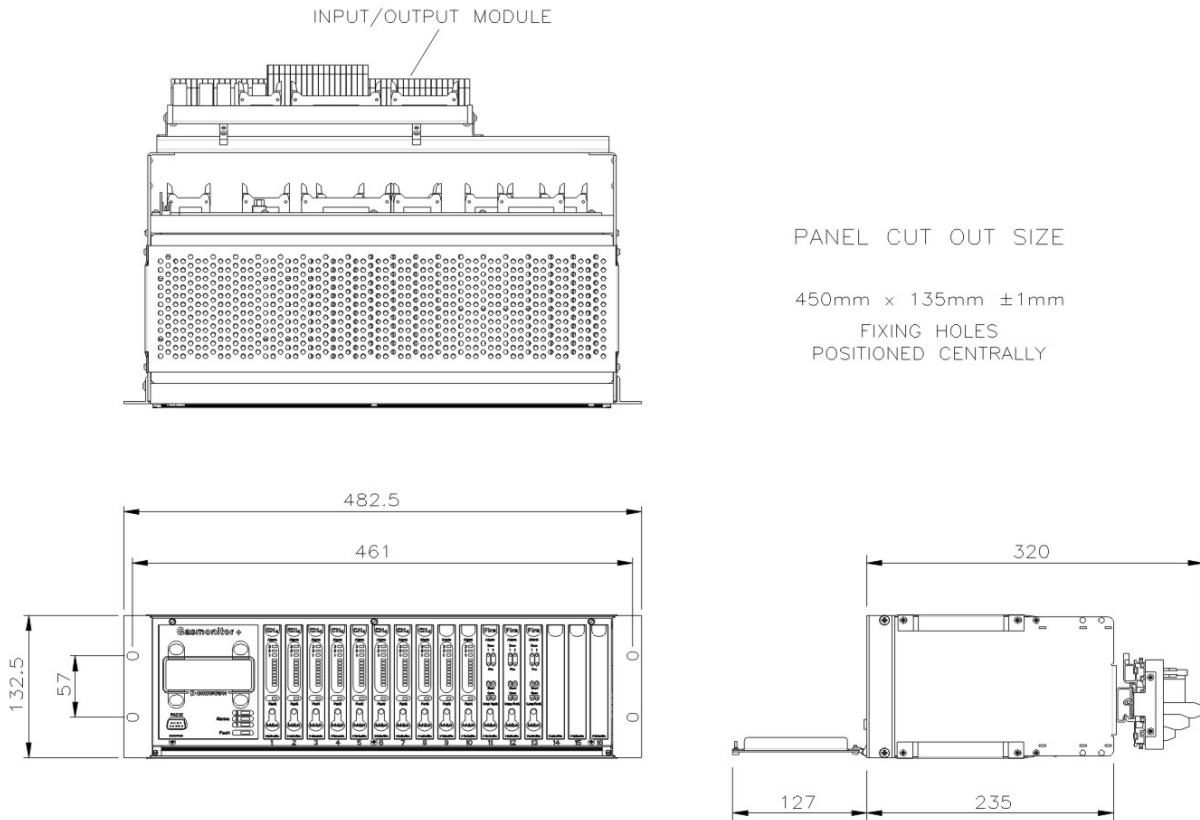

Figure 4: 19” Control Rack Mounting Detail (mm)

Note:

The Input/Output module and the Power Supply are shown mounted at the rear of the Gasmonitor+ rack. These can be removed and mounted in a more suitable location during the system installation.

HARDWARE

2.1.3 Electrical Connections

All electrical connections to field equipment are made via the DIN rail mounted modules mounted in the control cabinet (see later sections). These in turn are connected to the control rack motherboard via ribbon cables. Power connections are wired separately (see Power Distribution, Electrical Connections, section 2.7.4).

All control cards are fitted with appropriate plugs that slot into mating sockets on the motherboard when inserted into the rack.

Figure 5 details all electrical connections to be made to the Gasmonitor+ control rack motherboard.

2.1.4 Jumper Settings

If any intrinsically safe field device requires a Zener barrier to operate correctly then the link GND2 should be removed on the rear of the motherboard.

**FRONT VIEW OF RACK WITH DROP DOWN
PANEL OPEN AND ALL CONTROL
CARDS REMOVED**

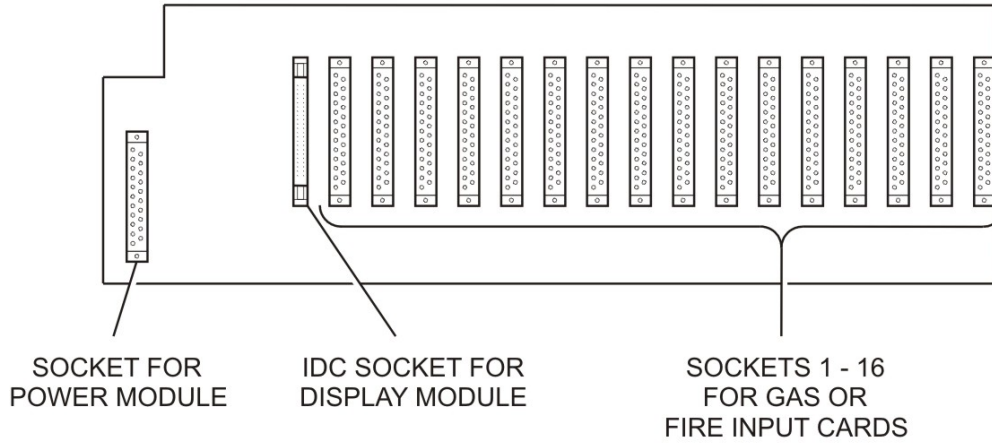

REAR VIEW OF RACK

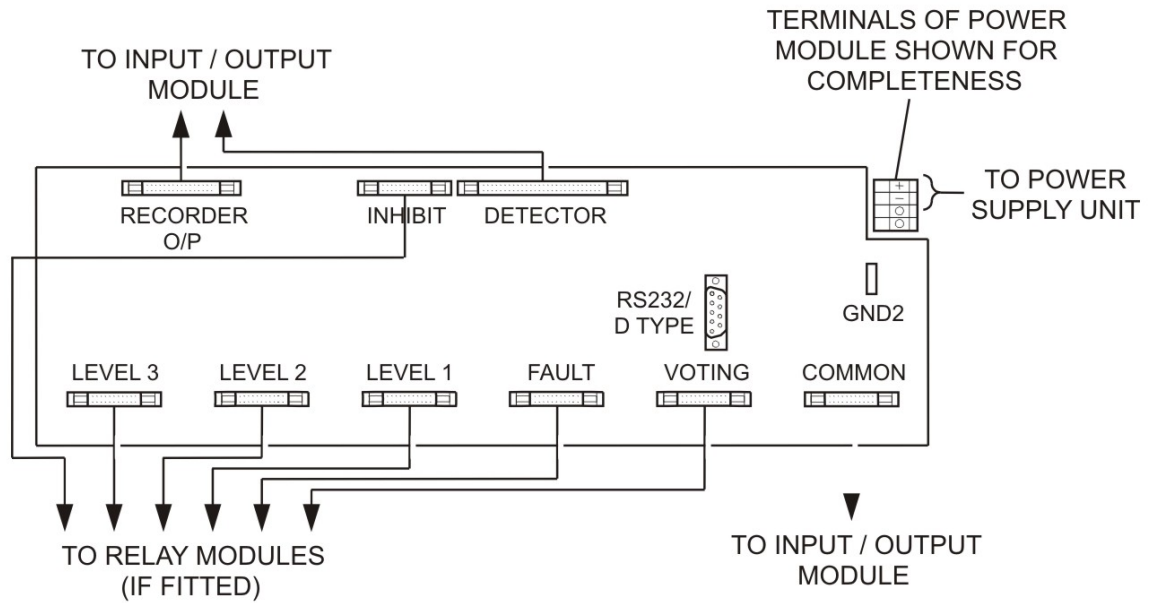

Figure 5: 19" Control Rack Electrical Connections, Front/Rear View

HARDWARE

2.2 Display Module

2.2.1 Description

Each Gasmonitor+ control rack is fitted with a Display Module that in normal operation details the status of the control rack and provides local user control of the system. Figure 6 gives a general view of the Display Module.

View with drop down front panel closed

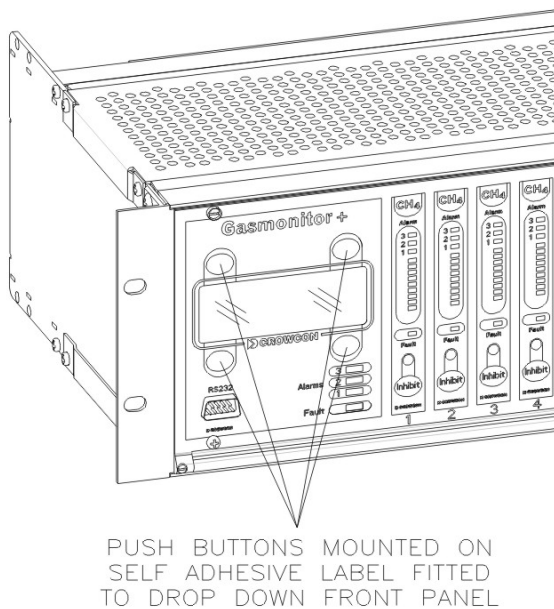

View with drop down front panel open

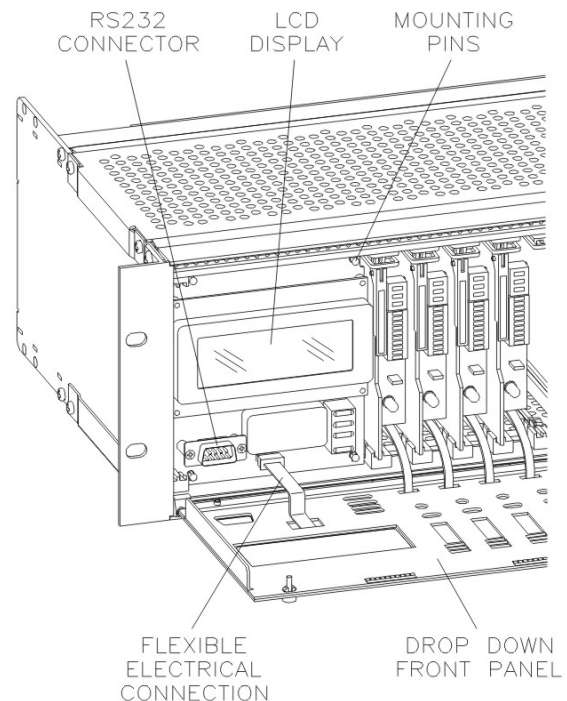

Figure 6: Display Module General View

The Display Module is operated by four pushbuttons mounted on the drop down front panel. The Display Module includes a backlit LCD display, common gas alarm and fault indicators, an internal sounder and an RS232 serial communications port (the RS232 port is also wired out to the motherboard).

The Display Module holds the systems configuration in battery backed RAM. The majority of the system settings may be adjusted using the menu system, e.g., calibration of individual channels or adjustment of alarm set points. For

details on how to make system configuration changes via the pushbutton on the Display Module see Appendix A.

A PC may be connected to the RS232 port and using the SetGmon software provided gives the user full access to all of the system settings. For SetGmon installation and operation details please refer to Appendix B.

Crowcon recommend that SetGmon be used to initially configure a system and the Display Module menu system is used for subsequent minor adjustments.

The Display Module controls the internal sounder, common alarm relays and dedicated audible and visual alarm drives on the Input/Output Module (see Input/Output Module, Description, section 2.5.1).

The Display Module is able to drive up to 16 relay outputs (called Voted Relays) that are user configurable via the SetGmon software provided. The relays are mounted on optional Relay Modules in the control cabinet (see Relay Module, Description, section 2.6.1).

2.2.2 Routine Operation

The four pushbuttons allow the user to navigate through the menu system shown on the LCD display. The function of each pushbutton changes depending on which menu is displayed. The function of each pushbutton is shown adjacent to that pushbutton on the LCD display. For a detailed explanation of all Display Module menus and pushbutton operations please refer to Appendix A.

2.2.2.1 Common Alarm Relay and LED Operation

The Display Module monitors the status of each gas and fire input card. Should any input card detect an alarm or fault condition the relevant LED will illuminate on the Display Module, the internal sounder and the appropriate common alarm relay will operate.

Mixed gas and fire input cards in the same control rack share common LEDs and alarm relays as follows:

Alarm Condition	Associated Common Alarm Relay on Input/Output Module	Associated Common LED on Display Module
Any zone 1 fire detected OR Level 1 gas detected	Level 1 relay	Alarm 1 LED
Any zone 2 fire detected OR Level 2 gas detected	Level 2 relay	Alarm 2 LED
Any level 3 gas detected	Level 3 relay	Alarm 3 LED
Any zone fault detected OR Any gas fault detected	Fault relay	Fault LED

As standard the common fault relay is normally energised, de-energising on a fault condition or loss of power and the common alarm relays are normally de-energised, energising on alarm. These settings may be changed via SetGmon.

Pressing the RESET button on the Display Module silences the audible alarm. If on pressing the RESET button, the alarm condition has cleared, the common alarm relays will reset and the appropriate LED will turn off.

2.2.2.2 Dedicated Audible and Visual Alarm Drive Operation

The Display Module can be used to drive audible and visual alarms mounted in the field. Field connections are made at the Input/Output Module (see Figure 17).

Four switched 24 V dc outputs (common 0 V dc return) are provided. Each output can supply 24 V dc at up to 200 mA. These outputs operate as follows:

Switched Output	Alarm Condition	Comment
LEVEL 1	Any zone 1 fire detected OR Level 1 gas detected	Audible alarm drive 1 Press RESET to silence
LEVEL 2	Any zone 2 fire detected OR Level 2 gas detected	Audible alarm drive 2 Press RESET to silence
LEVEL 3	Any level 3 gas detected	Audible alarm drive 3 Press RESET to silence
VIS	Any zone fire detected OR Any gas level detected	Visual alarm drive Can only be RESET once alarm condition has cleared

2.2.2.3 Voted Relay Operation

Up to 16 relays mounted on 2 x Relay Modules (see Figure 19) may be connected to the Display Module. Each relay may be individually configured using SetGmon.

The operation of the relay is dependant upon the configuration, for example, a relay may be set to operate given any 2 level 1 gas alarms being detected in a control rack (i.e., 2 out of 16 voting). Other voting or grouping arrangements are available (see Appendix B).

Grouped and Voted Relay outputs are normally de-energised, energising on alarm. The relay output will remain energised for as long as the alarm condition is present. Once the alarm condition has cleared then the relay may be cleared by pressing RESET on the Display Module.

2.2.2.4 Fault Messages

Should any input card be removed while the system is in normal operation then the Display Module will indicate a 'Card XX Fail' (where XX is the position of the control card in the rack), the internal sounder and common fault relay will operate. To reset the system re-insert the input card and press RESET after waiting 10 seconds.

If the main 24 VDC power supply is lost, the system automatically switches over to the battery back-up (stand-by battery). The Display Module then monitors the battery voltage until it has discharged to a point where any further discharge will prevent the operation of the Gasmonitor+. At this stage, the internal audible alarm is initiated (this can be accepted by pressing the RESET button) and the display message changes to "**DC IN nn.nn VOLTS**". If loss of power continues, the battery isolation relay on the Input/Output Module disconnects the stand-by battery from the Gasmonitor+ rack to prevent it from being over-discharged and permanently damaged.

2.2.3 Mounting Detail

The Display Module is mounted behind the drop down front panel of the control rack in the leftmost position. It is held in position by four pins as shown in Figure 7.

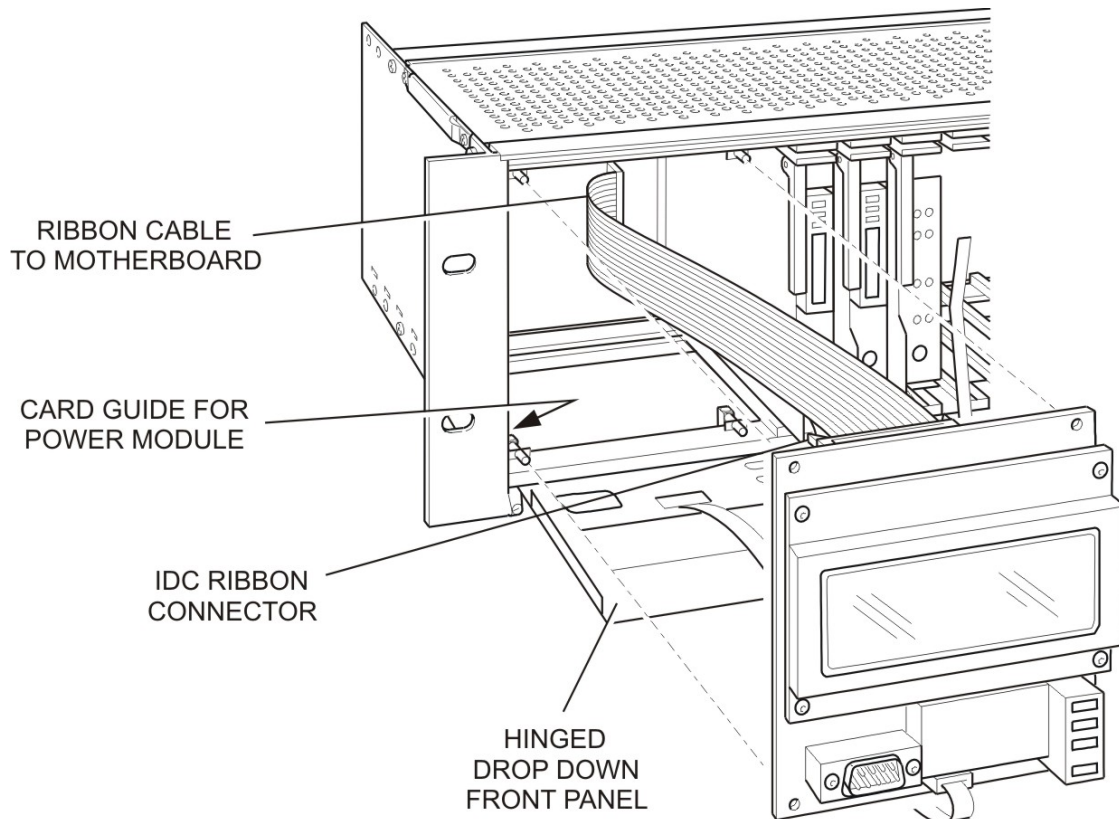
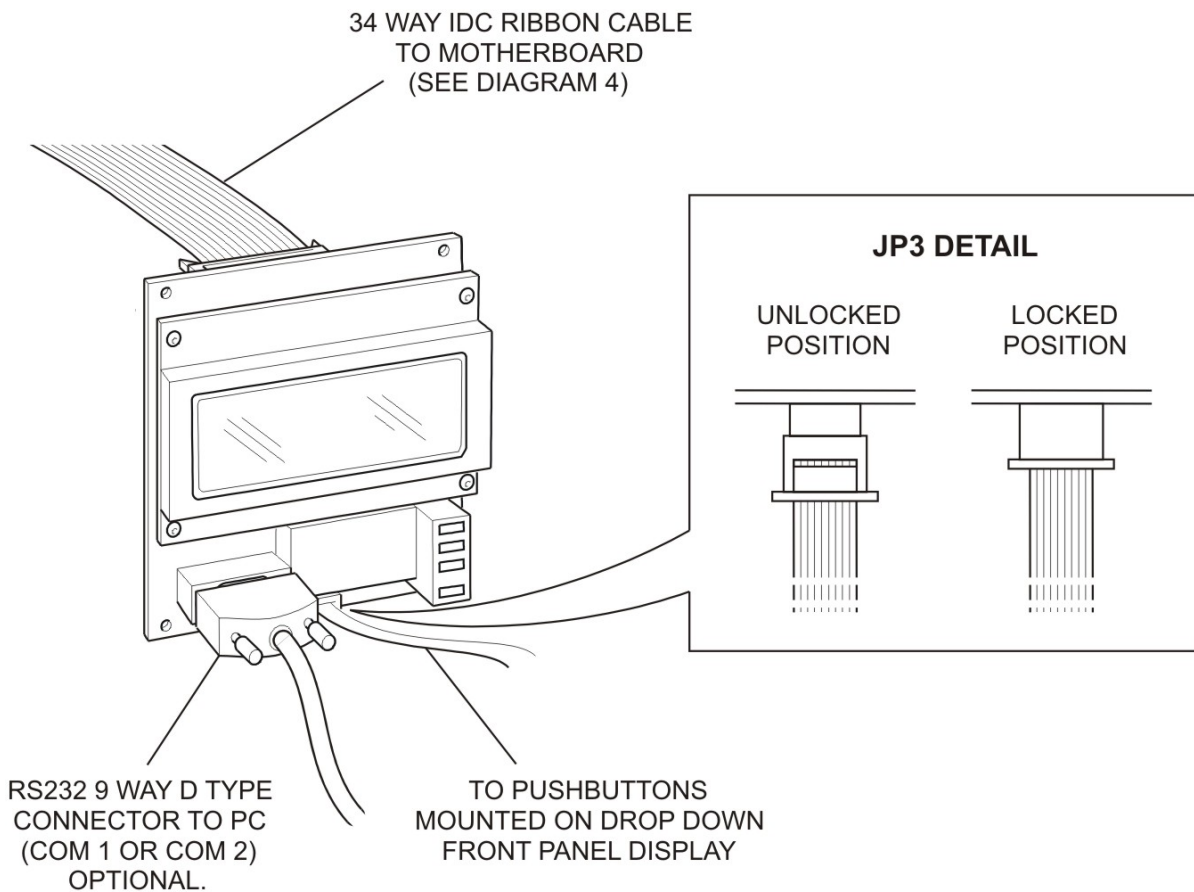

Figure 7: Display Module Mounting Detail

2.2.4 Electrical Connections

Figure 8 details all electrical connections to be made to the Display Module. When fitting cables care should be taken to ensure that all connections are secure.

All connections are made via the Input/Output and Relay Modules. Refer to Input/Output Module, Electrical Connections, section 2.5.3, and Relay Module, Electrical Connections, section 2.6.3.



HARDWARE

Figure 8: Display Module Electrical Connections

2.3 Universal Gas Input Card

2.3.1 Description

The Universal Gas Input Card is used to power and control remote flammable or toxic gas detectors. The control card has been designed to drive any of Crowcon's remote gas detectors but may be used to drive other devices given advice from Crowcon. The type of gas monitored by the detector fitted to the input card is labelled at the top of the front display.

Figure 9 gives a general view of the input card with the drop down front panel of the control rack closed.

HARDWARE

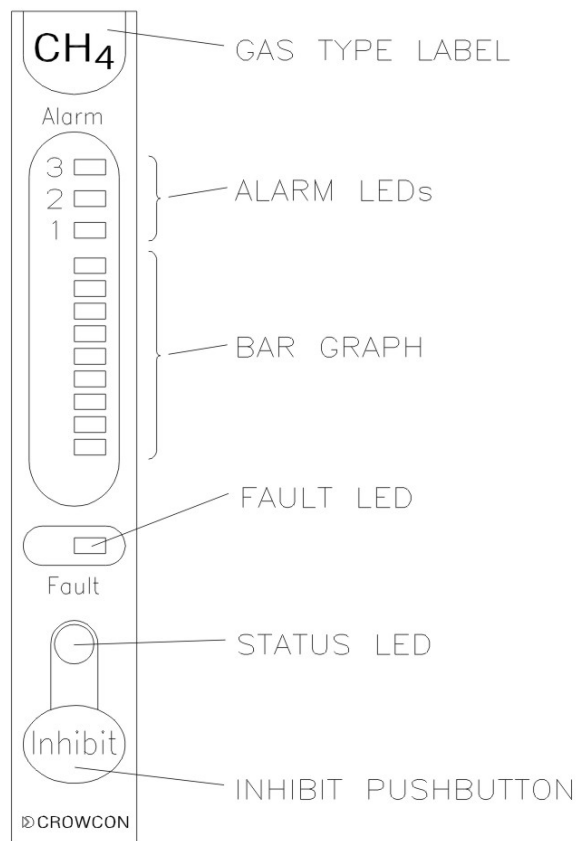

Figure 9: Universal Gas Input Card General View

The Universal Gas Input Card includes three levels of gas alarm and fault monitoring as standard. Three red LEDs indicate gas alarms (levels 1, 2 and 3) and a single yellow LED indicates the fault alarm.

The bar graph provides the user with an immediate indication of the gas level at the detector, in relation to the first alarm level.

The Status LED indicates whether the card is operating correctly.

The Universal Gas Input Card is able to drive individual channel relays including 3 levels of gas alarm and a fault output. These relays are user configurable (see Appendix A and B). The relays are mounted on optional Relay Modules in the control cabinet (see Relay Module, Mounting Detail, section 2.6.2).

The card provides a repeated analogue output proportional to the gas concentration for connection to repeater panels as required.

2.3.2 Routine Operation

2.3.2.1 LED Indicators

Upon triggering an alarm the relevant LED will flash until the RESET button on the Display Module has been pressed. If, on pressing the RESET button, the alarm condition has cleared, the system resets. If not, then the alarm LED will change from flashing to a steady state.

Once the alarm condition has cleared. Pressing the RESET button on the Display Module will reset the LED.

The bar graph provides operators with an approximate indication of gas levels in the field. For flammable and toxic gas detectors the bar graph is scaled such that no LEDs are lit when there is no gas present and all LEDs are lit when the first level of alarm is reached. For oxygen detectors no LEDs are lit when normal levels of oxygen are present at the detector, i.e., 20.9%vv. Should the oxygen level fall or rise, a single LED on the bar graph will move down or up from the centre of the bar graph which is scaled from level 1 alarm (oxygen deficiency) to level 2 alarm (oxygen enrichment).

In normal operation the Inhibit LED flashes approximately every 2 seconds indicating that communications between the Display Module and Universal Gas Input Card are working correctly. If the LED is permanently on, the input card is inhibited (see section 2.3.2.2).

2.3.2.2 Channel Inhibit

The INHIBIT pushbutton is mounted on the drop down front panel. Pressing the INHIBIT pushbutton on the input card and the RESET pushbutton on the Display Module simultaneously places the input card into standby mode. This is indicated by the Status LED remaining lit. In this state any alarm condition detected by the input card is not transmitted to the Display Module and no individual channel alarm relays can be activated. Pressing the INHIBIT pushbutton alone returns the control card to normal operation.

2.3.2.3 Individual Channel Alarm Relays

The Universal Gas Input Card can drive optional individual channel relays mounted on Relay Modules in the control cabinet (see Relay Module, Mounting Detail, section 2.6.2). Outputs include gas alarm level 1, 2 and 3 and fault.

The fault relay is normally energised, de-energising on detection of a fault or loss of power. The relay can only be reset once the fault condition has cleared and the RESET button on the Display Module is pressed.

Gas alarm relays (level 1, 2 and 3) are normally de-energised, energising on alarm. They are normally configured to be latching, i.e., they can only be reset once the gas alarm has cleared and the RESET button on the Display Module is pressed.

Each system is configured differently and the System Specification Sheet supplied with each system should be consulted to check how the relays have been set up. For further information on changing the relay configuration see Appendix A and B.

2.3.2.4 Repeated Analogue Output

The Universal Gas Input Card provides a repeated analogue output proportional to the gas concentration. This is configured via link settings on the Universal Gas Input Card as either 1-5 V dc or 4-20 mA (see Figure 11).

1-5 V dc or 4-20 mA corresponds to no gas present at the detector to full-scale gas present at the detector.

2.3.3 Mounting Detail

The Universal Gas Input Card is mounted behind the drop down front panel of the control rack. Input cards slot into the control rack to the right of the Display Module using the card guides provided and are locked into position by a lever and catch. This is shown in Figure 10.

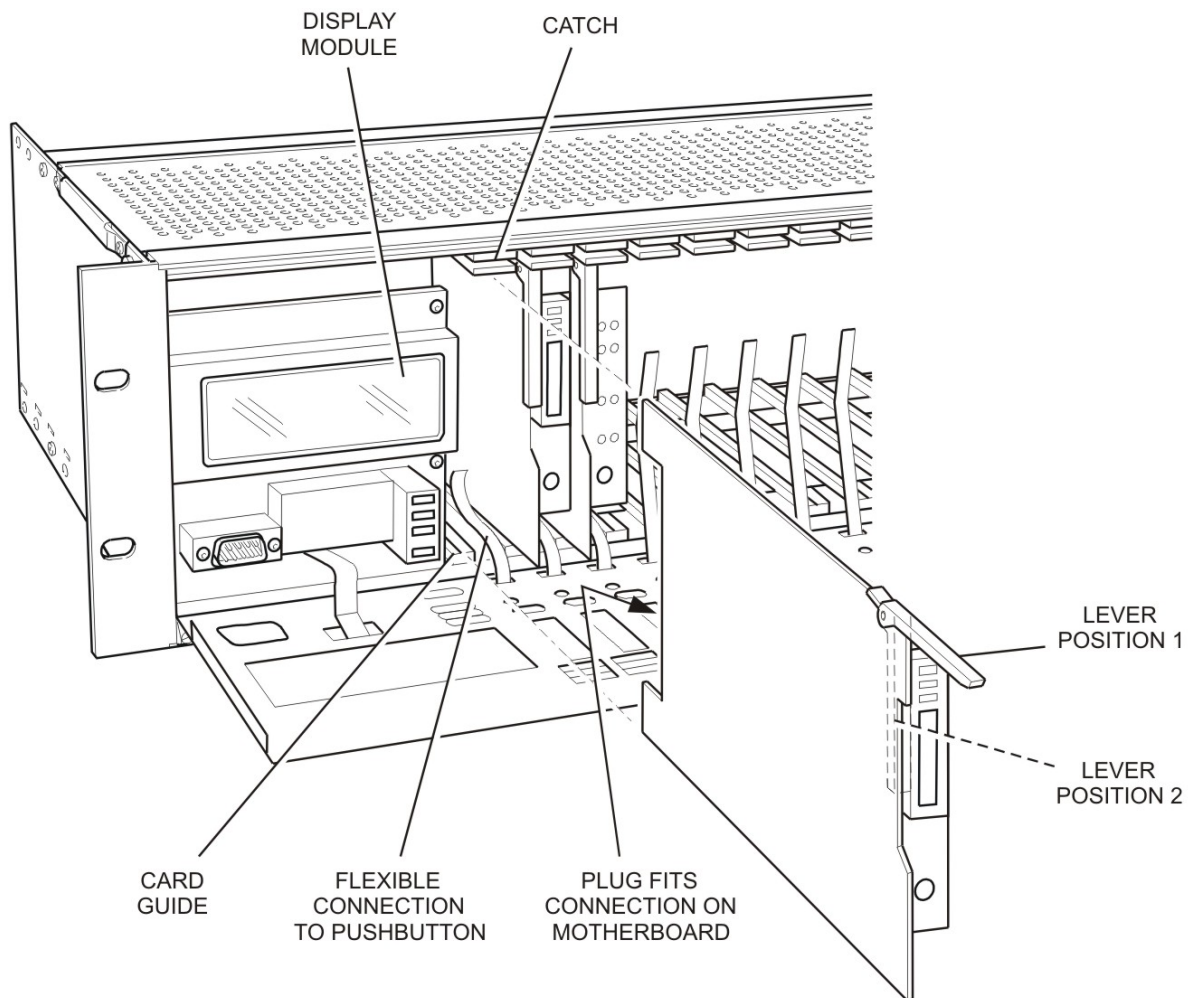

Figure 10: Universal Gas Input Card Mounting Detail

To remove or insert input cards the lever must be in position 1. Once the card is inserted fully into the rack pushing the lever down into position 2 locks the card into place.

2.3.4 Electrical Connections

The Universal Gas Input Card slots into the control rack. Electrical connections are made via the motherboard to the Input/Output Module and Relay Modules if fitted. All field connections are made via these modules.

The INHIBIT pushbutton is mounted on the drop down front panel. It is connected to the input card via the flexible cable shown in Figure 10. Care

should be taken to ensure that the flexible cable is fitted and locked into position before closing the front panel.

For details on field connections refer to Input/Output Module, Electrical Connections, section 2.5.3, and Relay Module, Electrical Connections, section 2.6.3.

2.3.5 Jumper Settings

The Universal Gas Input Card can be used with any Crowcon gas detector. Figure 11 details the links to be made for each type of gas detector that may be fitted.

LK3 adjusts the gain of the input amplifier of the control card. It is normally set to STD. Should a detector/input card be calibrated to a gas which gives a low signal when exposed to gas (e.g., pentane) then it may be necessary to set LK3 to HIGH or V.HIGH. Contact Crowcon for advice on setting this link. Incorrect positioning of LK3 will cause the CAL FAIL message to appear after a calibration attempt.

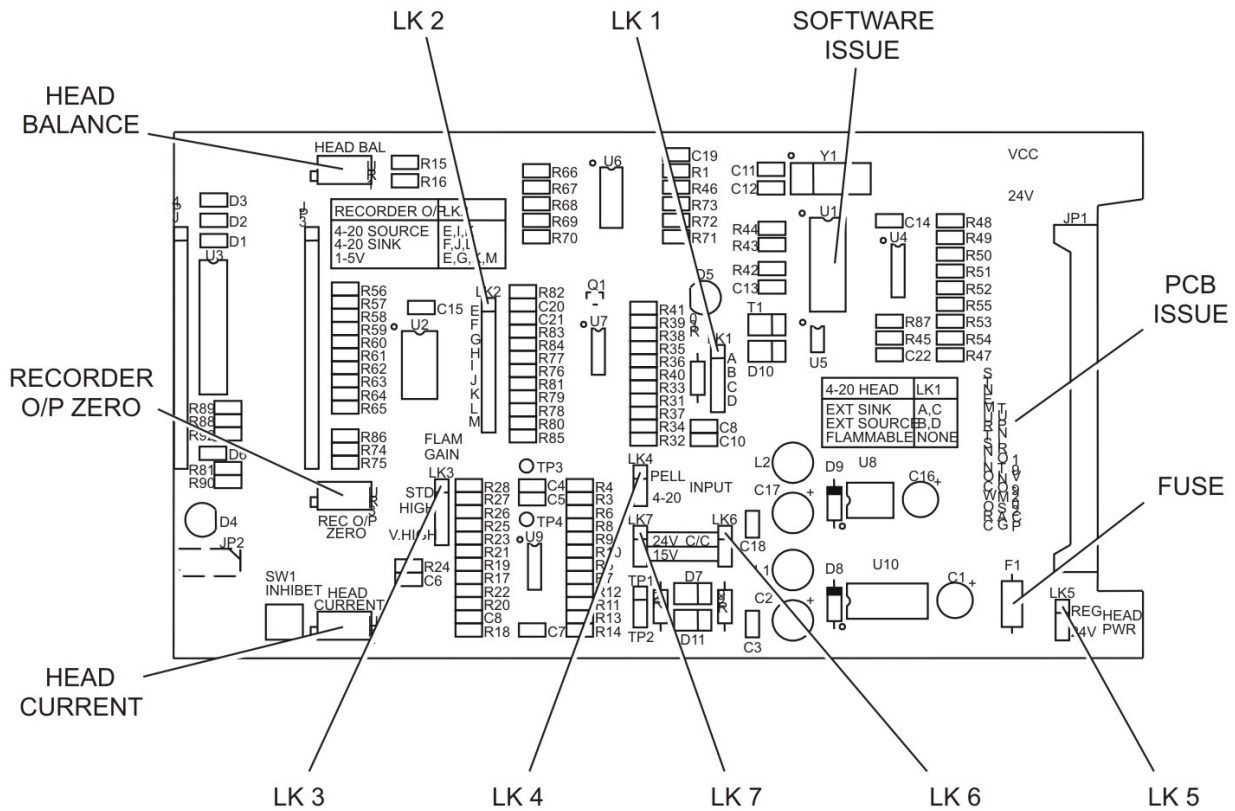

Figure 11: Universal Gas Input Card Jumper Locations

Link	Detector Type		
	Pellistor	2 wire 4 – 20 mA sink 24 V	3 wire 4 – 20 mA source 24 V
LK 1	None	A, C, A-B, C-D	B, D, B-C, D-E
LK 3	STD	None	None
LK 4	PELL	4 - 20	4 – 20
LK 5	REG	24 V	24 V
LK 6 & 7	24 V C/C	24 V C/C	24 V C/C

2.4 Twin Zone Fire Input Card

2.4.1 Description

The Twin Zone Fire Input Card is used to power and control conventional fire detectors including ionisation, optical and heat detectors. The input card can also be used to monitor manual alarm call points and unitised flame detectors.

Figure 12 gives a general view of the input card with the drop down front panel of the control rack closed.

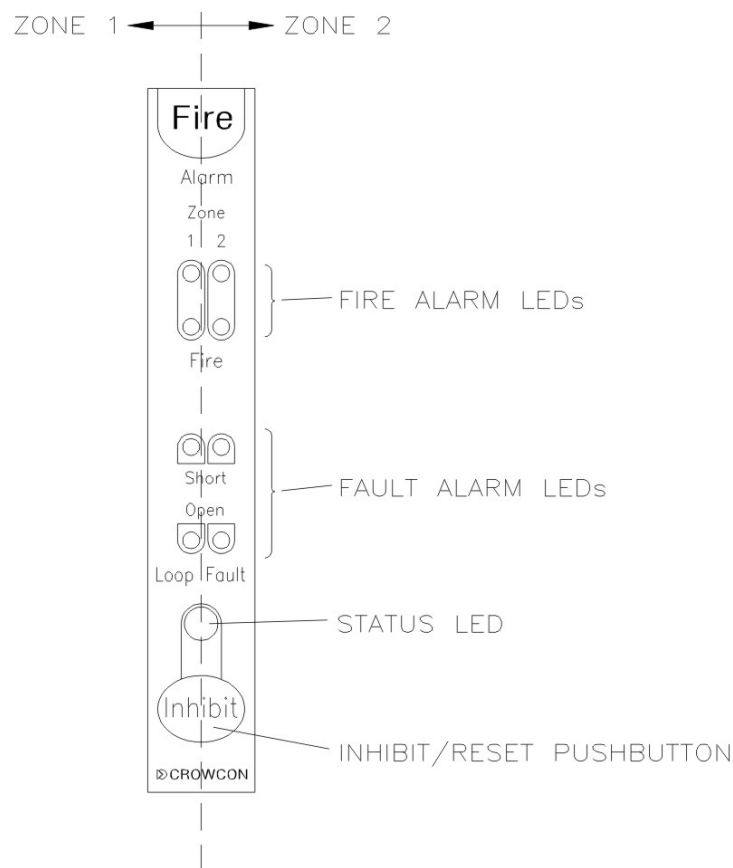

Figure 12: Twin Zone Fire Input Card General View

The Twin Zone Fire Input Card can monitor 2 loops of up to 20 conventional fire detectors. Each loop is used to monitor a specific area called a Zone. Each zone is monitored for fire alarms and loop faults (open and short circuit). These are indicated on the front of the card.

Fire LEDs (red) and LOOP FAULT LEDs (yellow) to the left of the input card show the status of detectors in zone 1, those on the right show the status of zone 2.

The Status LED indicates whether the card is operating correctly.

The Twin Zone Fire Input Card is able to drive individual zone alarm relays for fire and fault. These relays are user configurable (see Appendix A and B). The relays are mounted on optional Relay Modules in the control cabinet (see Relay Module, Description, section 2.6.1).

2.4.2 Routine Operation

2.4.2.1 LED Indicators

Upon triggering a fire alarm or fault alarm the relevant LEDs will illuminate. If, on pressing the INHIBIT/RESET button on the Twin Zone Fire Input Card, the alarm condition has cleared, the system resets. If not, then the alarm LED will remain on.

In normal operation the Status LED flashes approximately every 2 seconds indicating that communications between the Display Module and Twin Zone Fire Input Card are working correctly. If the Status LED is permanently on the input card is inhibited (see Channel Inhibit, section 2.4.2.2).

2.4.2.2 Channel Inhibit

The INHIBIT pushbutton is mounted on the drop down front panel. Pressing the INHIBIT pushbutton on the input card and the RESET pushbutton on the Display Module simultaneously places the input card into standby mode. This is indicated by the Status LED remaining lit. In this state any alarm condition detected by the input card is not transmitted to the Display Module and no individual channel or zone alarm relays can be activated. Pressing the INHIBIT button alone returns the control card to normal operation.

2.4.2.3 Individual Channel and Zone Alarm Relays

The Twin Zone Fire Input Card can drive optional individual zone alarm relays mounted on Relay Modules in the control cabinet. Outputs include fire detected zone 1, fire detected zone 2, fault detected zone 1, fault detected zone 2 and card inhibited.

The card inhibited relay is normally energised, de-energising whenever the input card is placed in standby mode (see section 2.4.2.2).

Individual zone fault relays are normally energised, de-energising on detection of a fault or loss of power. The relay can only be reset once the fault condition has cleared and the INHIBIT/RESET button on the Twin Zone Fire Input Card is pressed.

Individual fire alarm relays are normally de-energised, energising on alarm. They can only be reset once the fire alarm has cleared and the INHIBIT/RESET button on the Twin Zone Fire Input Card is pressed.

Each system is configured differently and the System Specification Sheet supplied with each system should be consulted to check how the relays have been set up. For further information on changing the relay configuration see Appendix A and B.

2.4.3 Mounting Detail

The Twin Zone Fire Input Card is mounted behind the drop down front panel of the control rack. Input cards slot into the control rack to the right of the Display Module using the card guides provided and are locked into position by a lever and catch. This is shown in Figure 13.

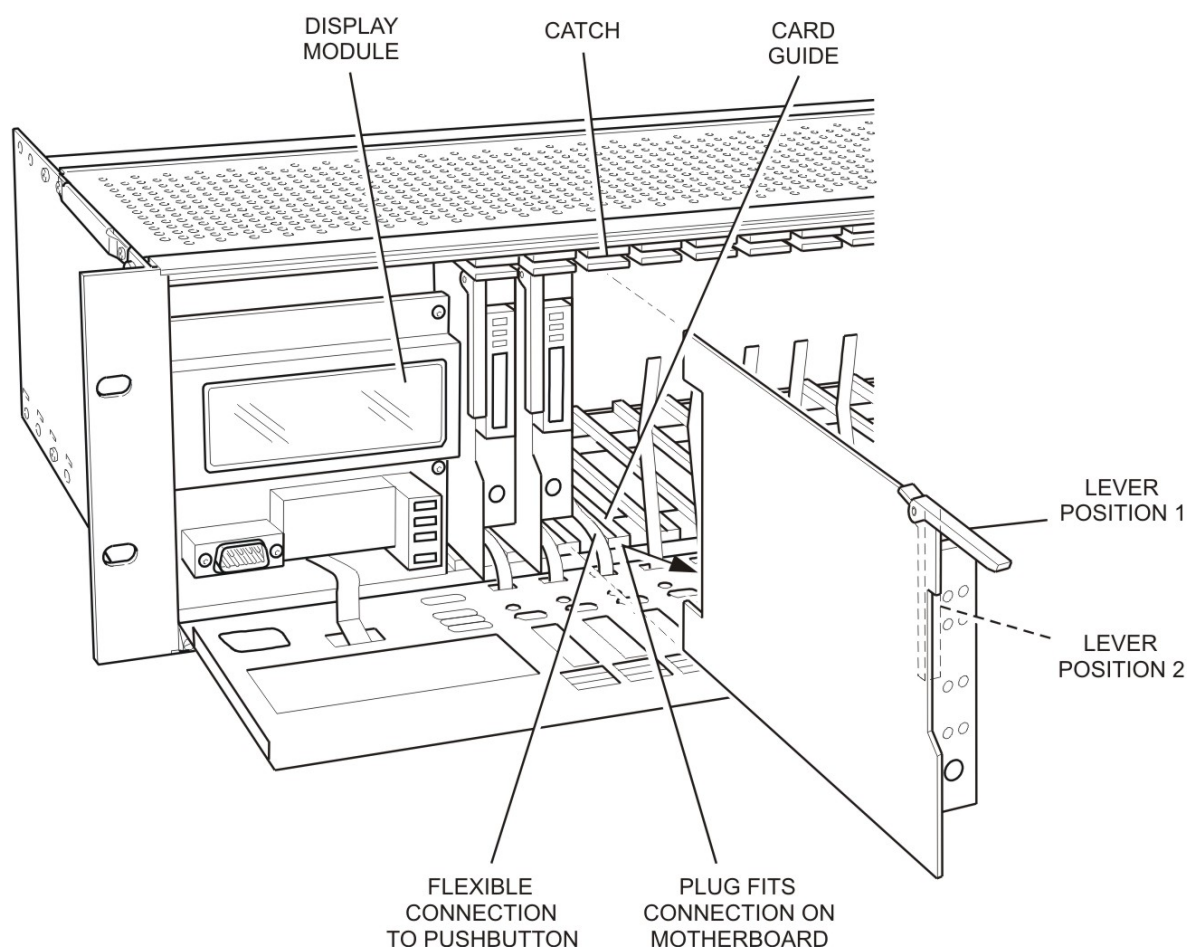

Figure 13: Twin Zone Fire Input Card Mounting Detail

To remove or insert input cards the lever must be in position 1. Once the card is inserted fully into the rack pushing the lever down into position 2 locks the card into place.

2.4.4 Electrical Connections

The Twin Zone Fire Input Card slots into the control rack. Electrical connections are made via the motherboard to the Input/Output Module and Relay Modules if fitted. All field connections are made via these modules. See Input/Output Module, Electrical Connections, section 2.5.3, and Relay Module, Electrical Connections, section 2.6.3.

The INHIBIT pushbutton is mounted on the drop down front panel. It is connected to the input card via the flexible cable shown in Figure 13. Care

should be taken to ensure that the flexible cable is fitted and locked into position before closing the front panel.

For details on field connections refer to Input/Output Module, Electrical Connections, section 2.5.3.

2.4.5 Jumper Settings

LK1 should be fitted if the field devices in the associated zone are to be used with a Zener barrier. This is shown in Figure 14.

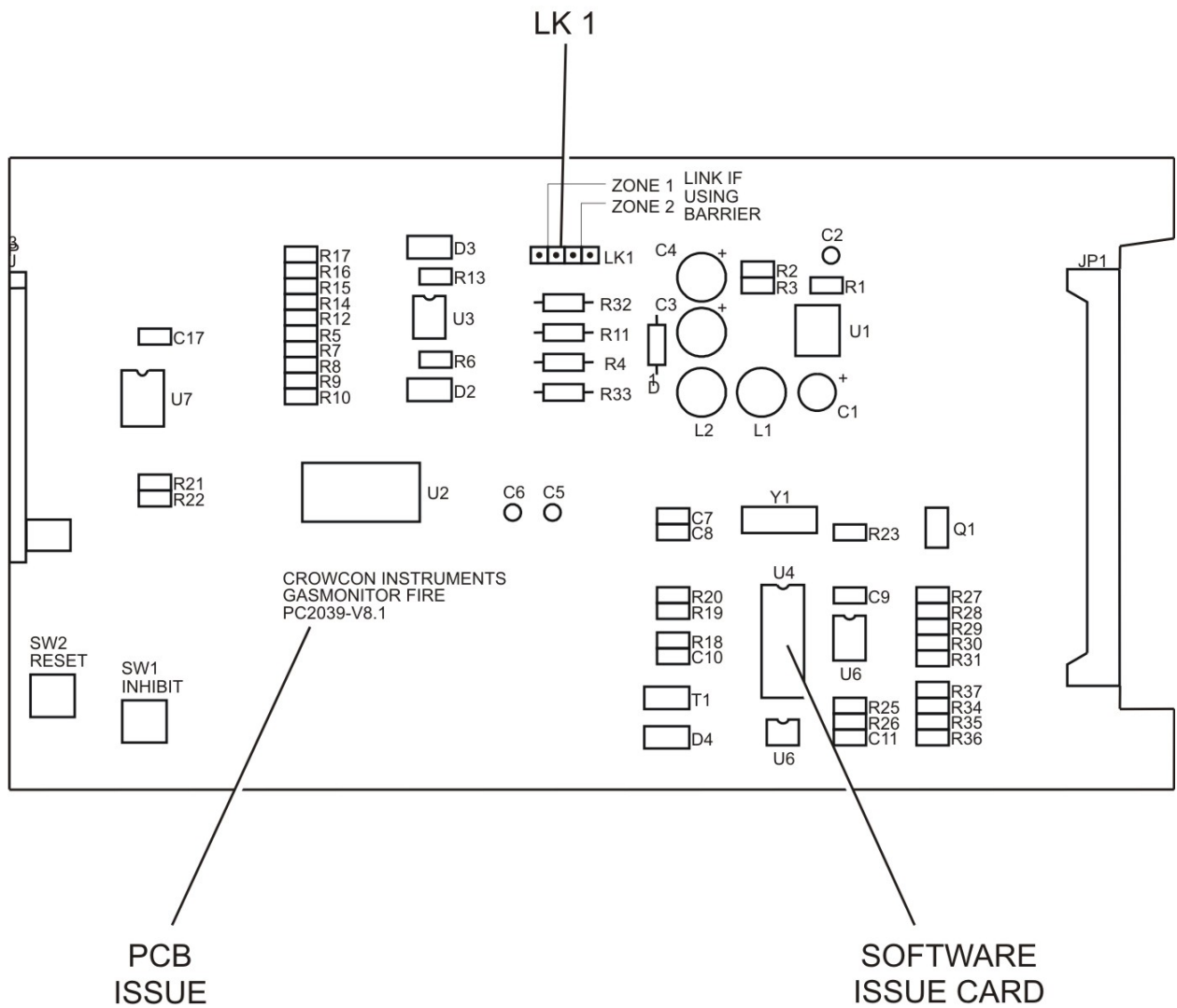

Figure 14: Twin Zone Fire Input Card Jumper Locations

2.5 Input/Output Module

2.5.1 Description

Each Gasmonitor+ control rack is supplied with one Input/Output (IO) Module. This module provides basic electrical connections to the system. These include connections to and from:

Gas and fire detectors.

Power supply unit and batteries for backup purposes.

Remote reset pushbutton (optional).

Audible and visual alarm drives (optional).

Common gas and fire alarm relays.

Common fault alarm relay.

Analogue outputs 4 - 20 mA or 1 - 5 V dc

Figure 15 gives a general view of the IO Module.

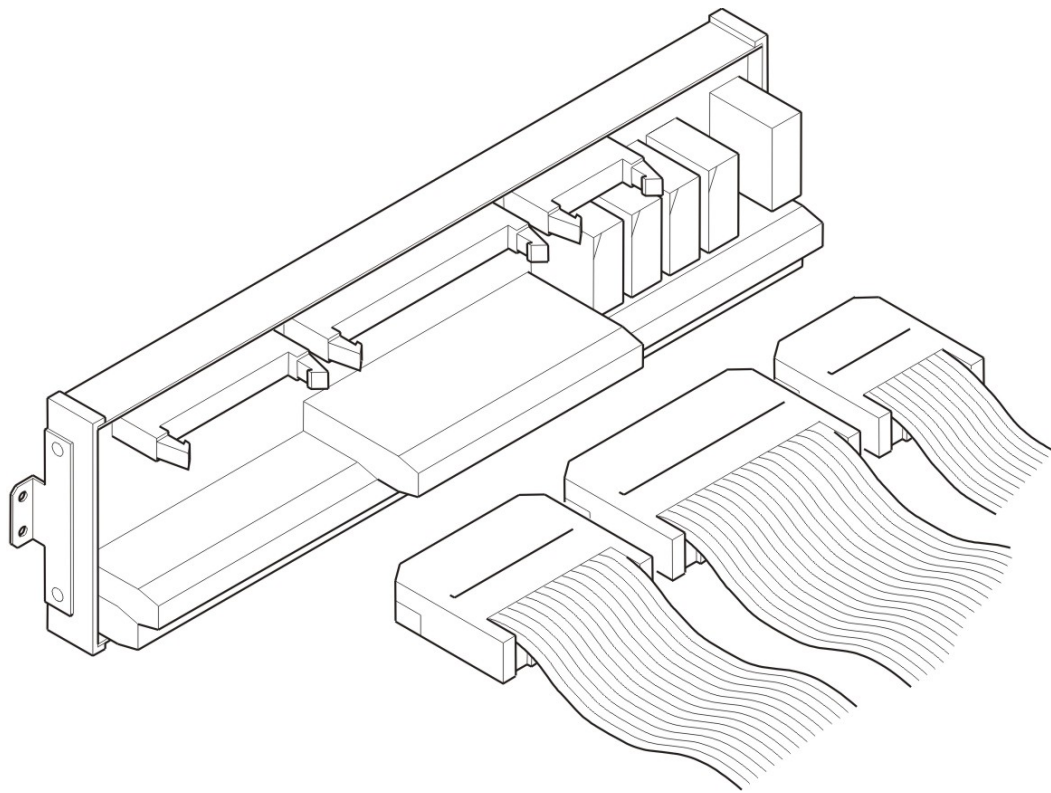

Figure 15: Input/Output Module General View

HARDWARE

2.5.2 Mounting Detail

The IO Module is mounted on standard TS32 or TS35 DIN rail in the control cabinet. Figure 16 gives overall mounting detail.

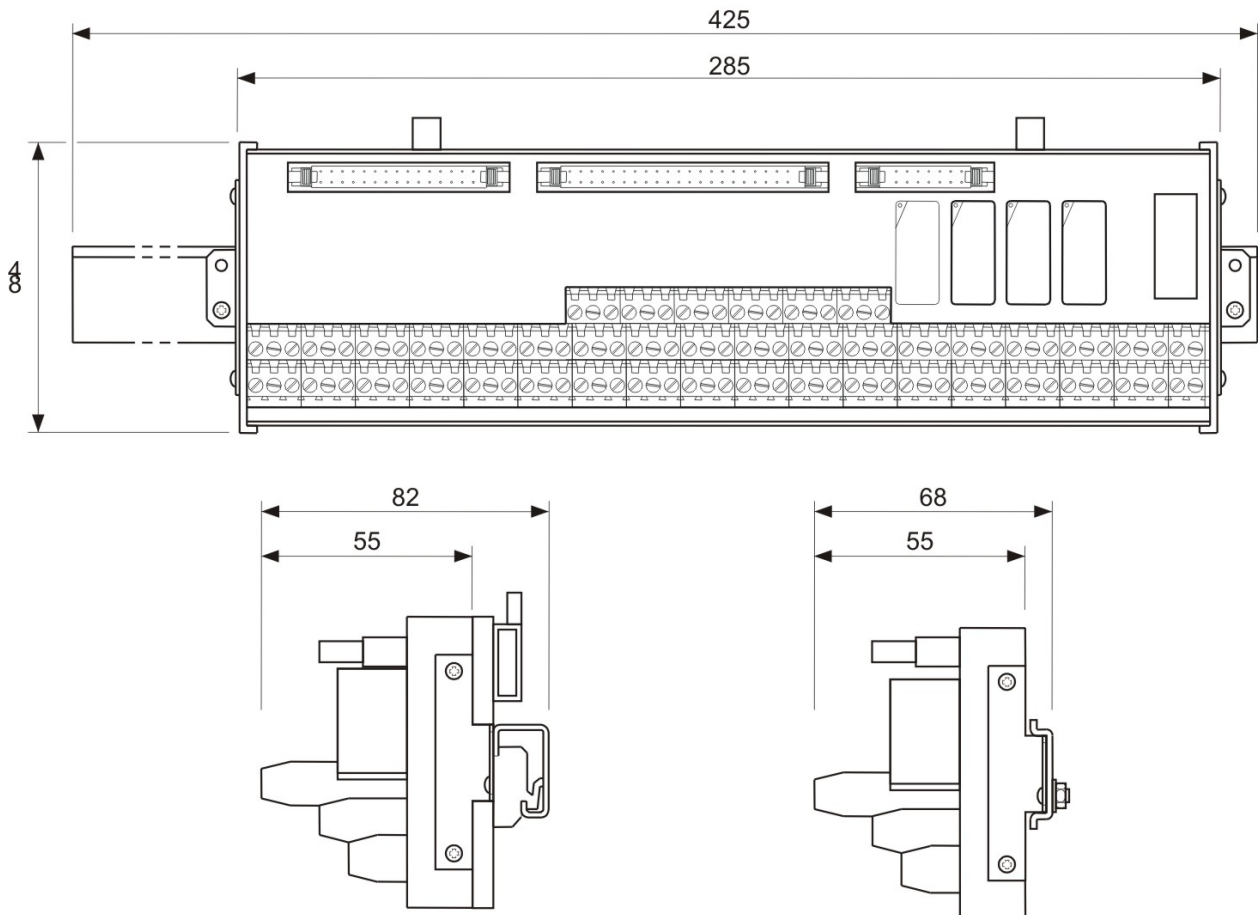

Figure 16: Input/Output Module Mounting Detail (mm)

2.5.3 Electrical Connections

The IO Module is connected to the control rack motherboard via ribbon cable as detailed in Figure 15. For details on motherboard connections see Figure 5.

Figure 17 summarises all available customer connections to the IO Module.

GASMONITOR INPUT / OUTPUT MODULE												
RACK No.:												
1	0V			Y1/4 24 VDC		OUTPUT		VIS	54			
3								LEV 3	55			
6	RESET I/P							LEV 2	53			
5								LEV 1	51			
8	BATTERY O/P							COM	50			
7								1	NO 23			
10	24 VDC TO RACK							2	COM 24			
9									NC 25			
12	24 VDC INPUT								NO 20			
11									COM 21			
62	+								NC 22			
61	S	1							1	NO 29		
60	-								2	COM 30		
65	+									NC 31		
64	S	2								NO 26		
63	-									COM 27		
68	+									NC 28		
67	S	3								NO 35		
66	-									COM 36		
71	+									NC 37		
70	S	4								NO 32		
69	-									COM 33		
74	+									NC 34		
73	S	5								NO 41		
72	-									COM 42		
77	+									NC 43		
76	S	6								NO 38		
75	-									COM 39		
80	+									NC 40		
79	S	7							1	+	121	
78	-									-	120	
83	+									2	+	123
82	S	8								-	122	
81	-									3	+	125
86	+									-	124	
85	S	9								4	+	127
84	-									-	126	
89	+									5	+	129
88	S	10								-	128	
87	-									6	+	131
92	+									-	130	
91	S	11								7	+	133
90	-									-	132	
95	+									8	+	135
94	S	12								-	134	
93	-									9	+	137
98	+									-	136	
97	S	13								10	+	139
96	-									-	138	
101	+									11	+	141
100	S	14								-	140	
99	-									12	+	143
104	+									-	142	
103	S	15								13	+	145
102	-									-	144	
107	+									14	+	147
106	S	16								-	146	
105	-									15	+	149
										-	148	
										16	+	151
										-	150	

Figure 17: Input/Output Module Terminal Detail

This is an electrical interconnection diagram only. The actual physical layout of terminals is as shown in Figure 16.

HARDWARE

All terminals are suitable for use with 0.5mm² to 2.5mm² cable.

All relays are rated 5 A, 240 V ac.

For details on connecting field devices to the IO Module refer to the following sections:

- 95.1 Remote gas and fire detectors: Field Devices, Gas Detector Installation and Operation , section 3.2, and Fire Detector Installation and Operation, section 3.3.
- 95.2 Audible and visual alarms: Field Devices, Audible/Visual Alarm Installation, section 3.4.
- 95.3 Power supply (including battery backup): Hardware, Power Distribution Electrical Connections, section 2.7.4.
- 95.4 Remote RESET pushbutton.

2.6 Relay Module

2.6.1 Description

Optional Relay Modules may be fitted to the system to provide individual channel alarm relay outputs including gas and fire alarms and a fault signal. These relays are controlled by the individual gas and fire input cards (see Appendix A and B for configuration and options).

Alternatively Relay Modules may be fitted to the system to provide up to 16 grouped alarm relay outputs (Voted Relay outputs). Grouped or voted relays are controlled by the Display Module (see Appendix A and B for configuration and options).

The Relay Module includes 8 x DPCO (Double Pole Change Over) relays and necessary screw terminal for customer use.

A yellow LED next to each relay indicates the relay status (LED on = energised, LED off = de-energised).

Figure 18 gives a general view of a Relay Module.

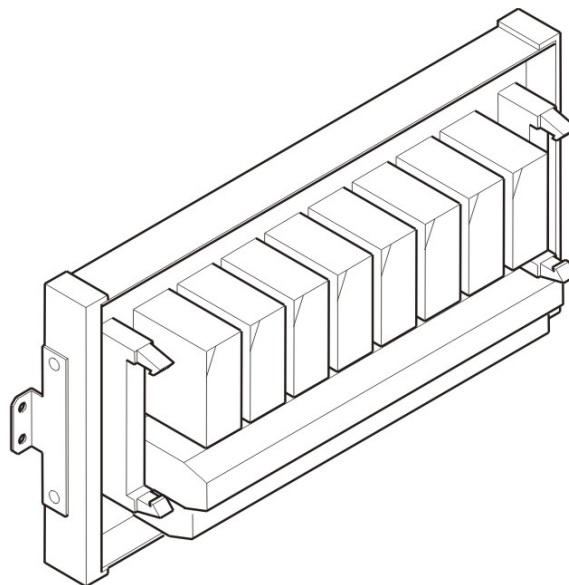

Figure 18: Relay Module General View

2.6.2 Mounting Detail

Relay Modules are mounted on standard TS32 or TS35 DIN rail in the control cabinet. Figure 19 gives the overall mounting detail.

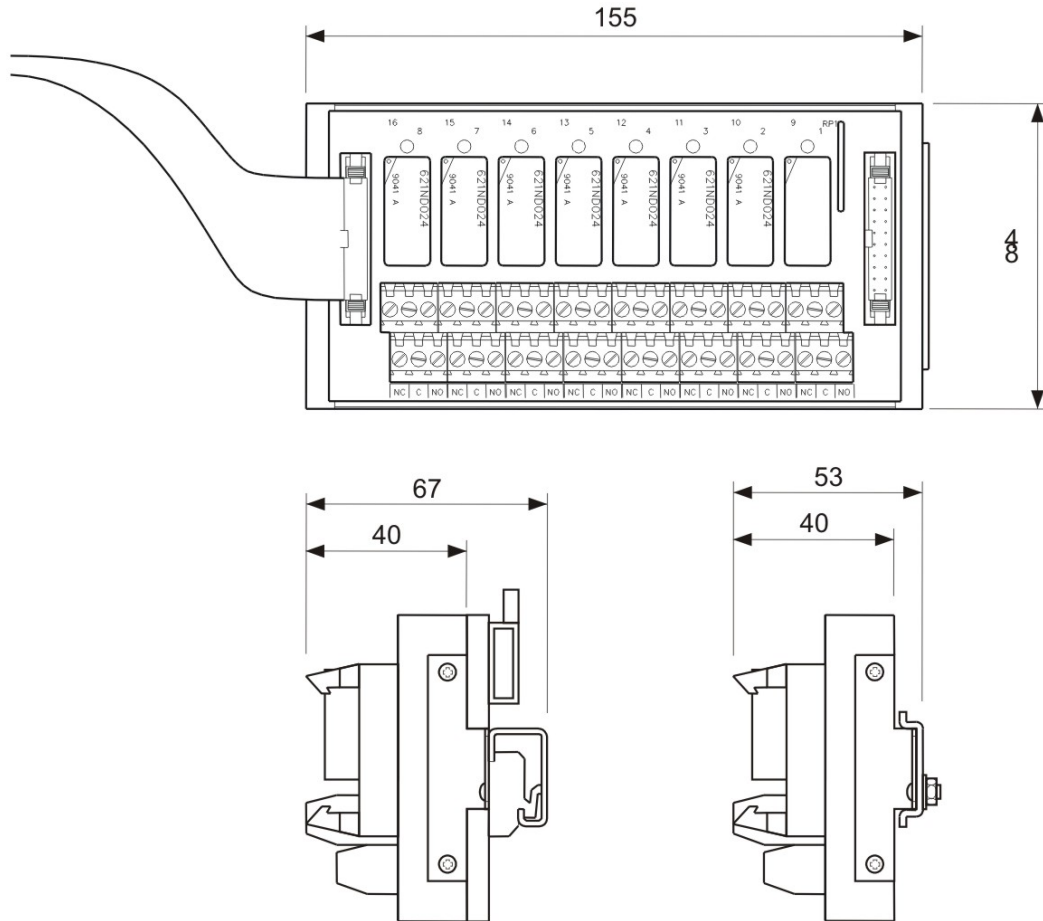

Figure 19: Relay Module Mounting Detail (mm)

HARDWARE

2.6.3 Electrical Connections (General)

The relay module is connected to the control rack motherboard via ribbon cable. The maximum length of ribbon cable allowed is 10m.

Each Relay Module contains 8 x DPCO relays rated 5A at 250 V ac (non inductive load).

All terminals are suitable for use with 0.5mm² to 2.5mm² cable.

Figure 20 summarises all available customer connections to a Relay Module.

GASMONITOR RELAY MODULE							
RACK Nb.:			MODULE Nb.:				
RELAYS 1 - 8				RELAYS 9 - 16			
1	NC	1	1	5	1	NC	25
2	COM					COM	26
3	NO	2	9	13	2	NO	27
4	NC					NC	28
5	COM	1	2	6	1	COM	29
6	NO					NO	30
7	NC	2	10	14	2	NC	31
8	COM					COM	32
9	NO	1	3	7	1	NO	33
10	NC					NC	34
11	COM	2	11	15	2	COM	35
12	NO					NO	36
13	NC	1	4	8	1	NC	37
14	COM					COM	38
15	NO	2	12	16	2	NO	39
16	NC					NC	40
17	COM	1	4	8	1	COM	41
18	NO					NO	42
19	NC	2	12	16	2	NC	43
20	COM					COM	44
21	NO	1	3	7	1	NO	45
22	NC					NC	46
23	COM	2	12	16	2	COM	47
24	NO					NO	48

Figure 20: Relay Module Terminal Detail

This is an electrical interconnection diagram only. The actual physical layout of terminals is as shown in Figure 19.

2.6.3.1 Electrical Connections (Individual Channel Alarms – Gas Only)

The Universal Gas Input Card can drive individual channel relays mounted on the Relay Module (see Universal Gas Input Card, Routine Operation, Individual Channel Alarm Relays, section 2.3.2.3). Figure 21 summarises the connections.

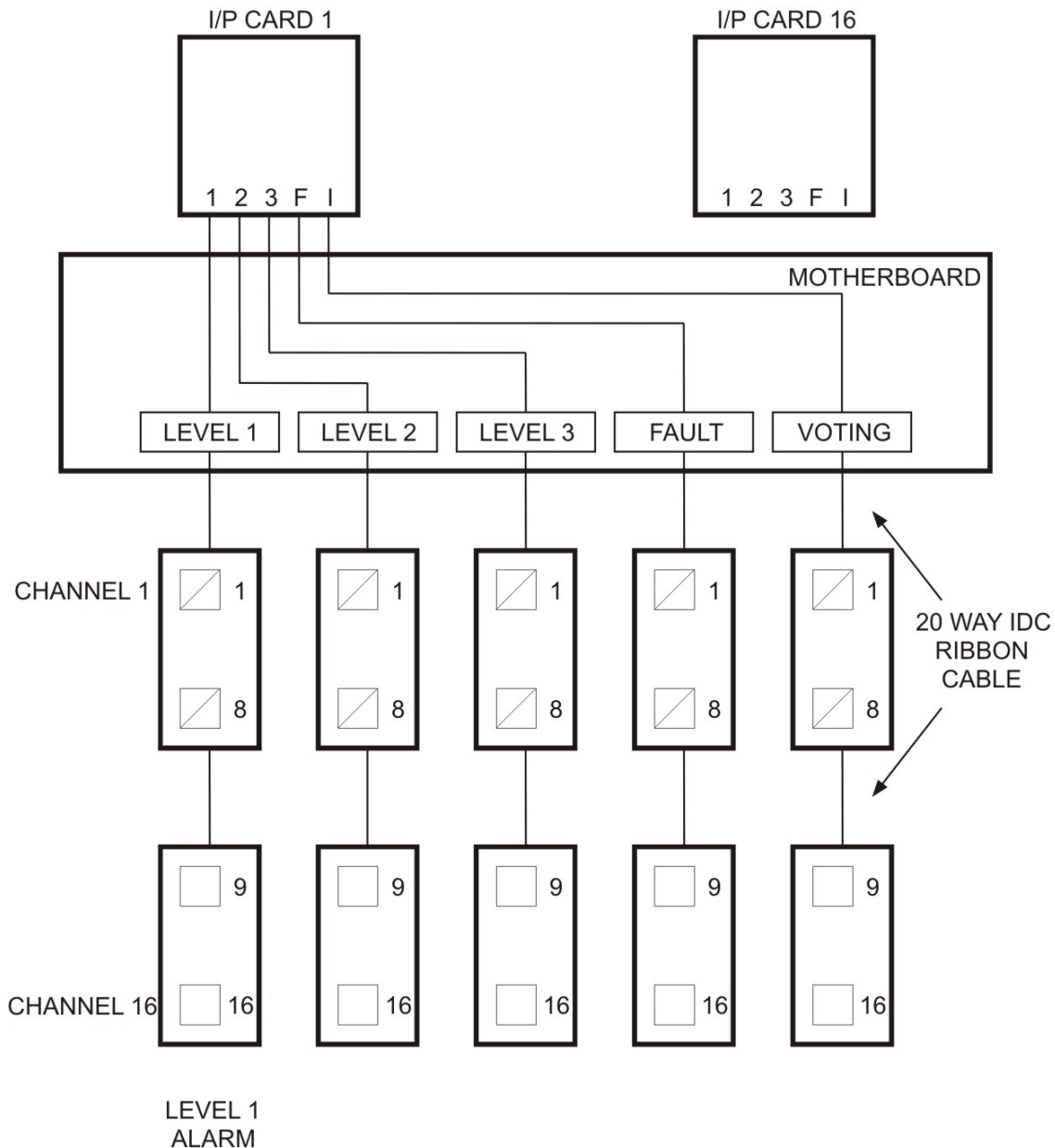
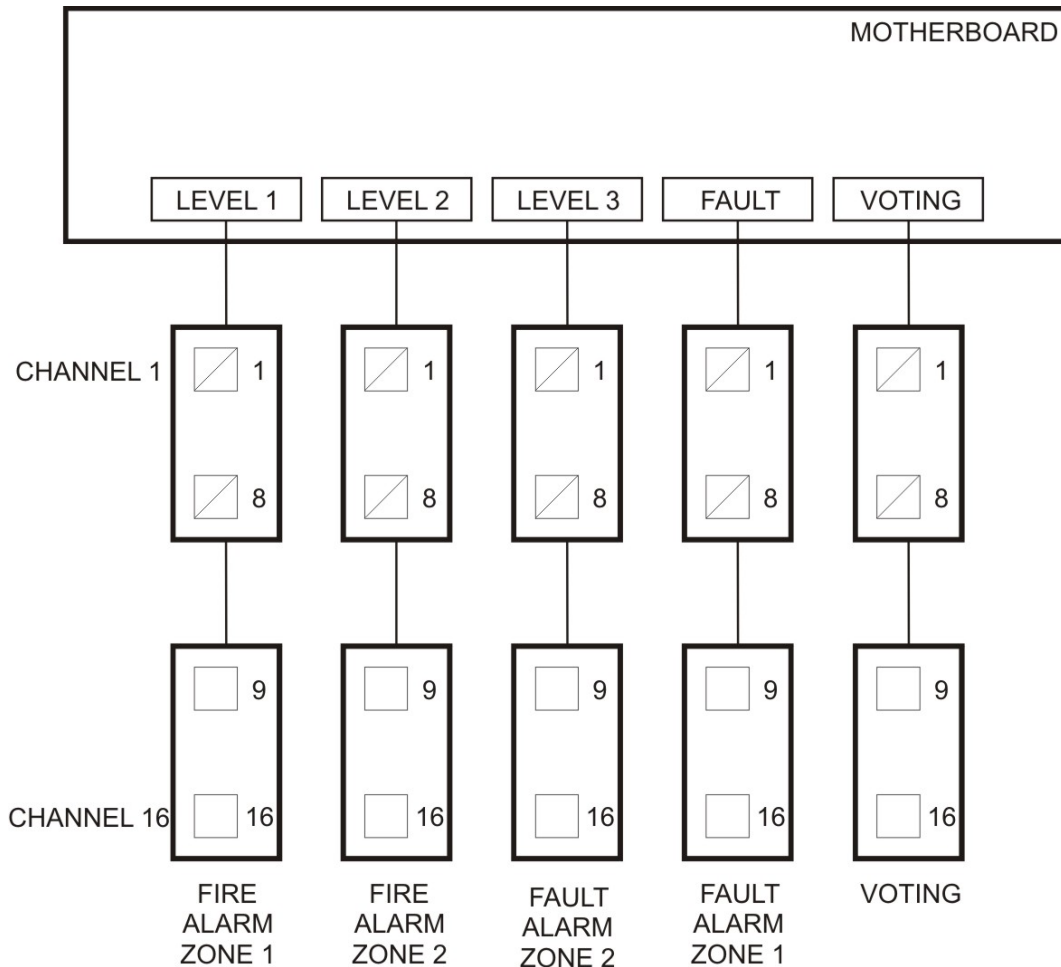

Figure 21: Relay Module Electrical Connections

2.6.3.2 Electrical Connections (Individual Channel Alarms – Fire Only)

The Twin Zone Fire Input Card can drive individual channel relays mounted on the Relay Module (see Twin Zone Fire Input Card, Routine Operation, Individual Channel and Zone Alarm Relays, section 2.4.2.3). Figure 22 summarises the connections.



HARDWARE

Figure 22: Relay Module Electrical Connections

2.6.3.3 Electrical Connections (Voted Relays)

The Display Module can drive individual Voted Relays mounted on the Relay Module (see Display Module, Routine Operation, Voted Relay Operation, section 2.2.2.3). Figure 23 summarises the connections.

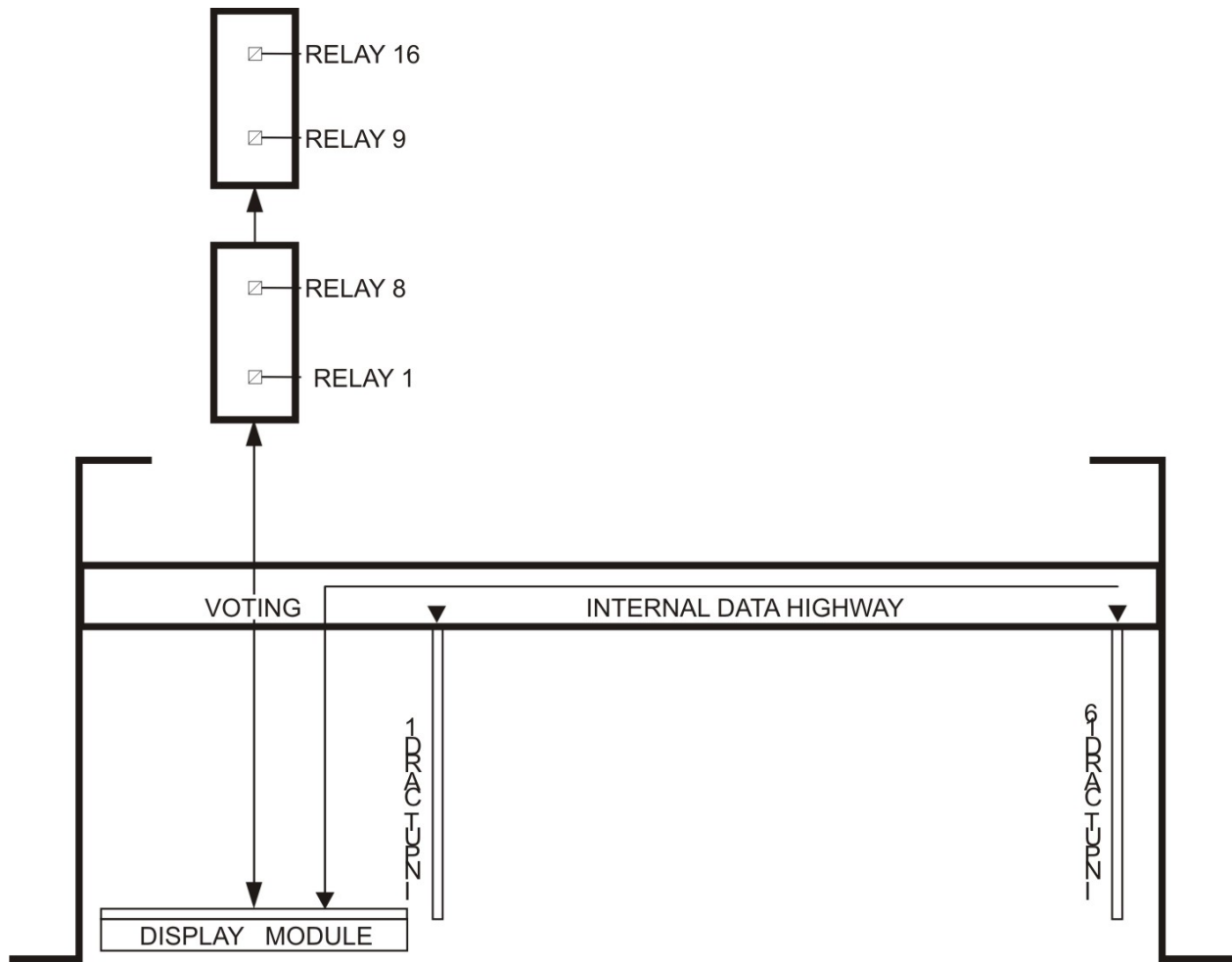

Figure 23: Relay Module Electrical Connections (Voted Relays)

2.7 Power Distribution

The following section describes the power distribution of a Gasmonitor+ gas and fire system with one control rack only. A Gasmonitor+ gas and fire control system may include more than one control rack and such systems can share Power Supply Units and standby batteries. For further details on the power distribution requirements of 'large' systems please contact Crowcon.

2.7.1 Description

As standard each Gasmonitor+ control rack is supplied with a Power Module, a suitably sized Power Supply Unit, an Input/Output Module and standby batteries for battery backup.

A Gasmonitor+ gas and fire control rack requires a clean supply of 18-30Vdc to operate correctly. The current consumption depends on the configuration of the system, i.e., number of detectors, relays and field devices.

The Power Module is mounted in the control rack. It accepts a nominal 24Vdc supply smoothes and filters it before distribution to control cards via the motherboard.

The Power Module also holds system fuses and driving circuitry for dedicated audible/visual field devices.

A Gasmonitor+ gas and fire system may be powered from a main supply of 100-260Vac, 50/60Hz. Depending upon the system configuration a 150W or 300W Power Supply Unit is mounted in the control cabinet and is used to convert the main supply to 24Vdc (nominally). See Power Distribution, Calculation of Power Supply Requirements and Battery Backup, Example Power/Battery Backup Calculation, section 2.7.5, for calculating power supply requirements.

Each Gasmonitor+ control rack is supplied with two 12Vdc, 7Ah sealed lead acid batteries (wired in series to provide a 24Vdc, 7Ah backup supply). The available backup time depends on the configuration of the system. See Power Distribution, Calculation of Power Supply Requirements and Battery Backup, Example Power/Battery Backup Calculation Step 3, in section 2.7.5.2, for typical backup calculations.

2.7.2 Routine Operation

If the main ac power supply is lost, the system automatically switches over to the stand-by battery operation.

The Display Module monitors the battery voltage until it has discharged to a point where any further discharge will prevent the operation of the system. At this stage, the internal audible alarm is initiated (this can be accepted by pressing the RESET button on the Display Module) and the message “**DC IN nn.nn VOLTS**” is displayed on the Display Module.

If loss of power continues, the battery isolation relay on the Input/Output Module disconnects the stand-by battery from the control rack to prevent it from being over-discharged and permanently damaged.

Under total power failure all system set up, configuration and logged data is protected by means of a battery-backed RAM in the Display Module.

During periods of power loss, further data will not be logged until power is reinstated.

Detectors have a warm-up time when power is initially connected, or re-connected after a power loss. During this period, detector signals may not be reliable.

2.7.3 Mounting Detail

2.7.3.1 Power Module

The Power Module is shown in Figure 24.

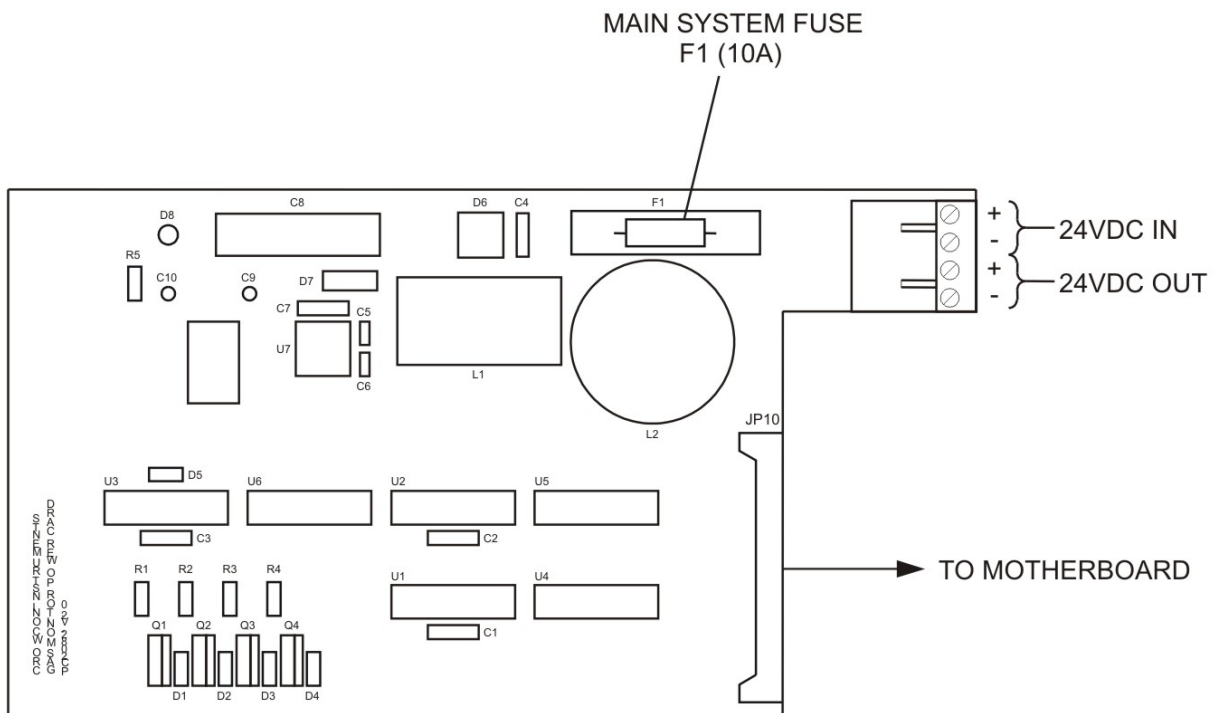

HARDWARE

Figure 24: Power Module General Arrangement

The Power Module Slots into the control rack behind the Display Module. See Figure 25 for detail.

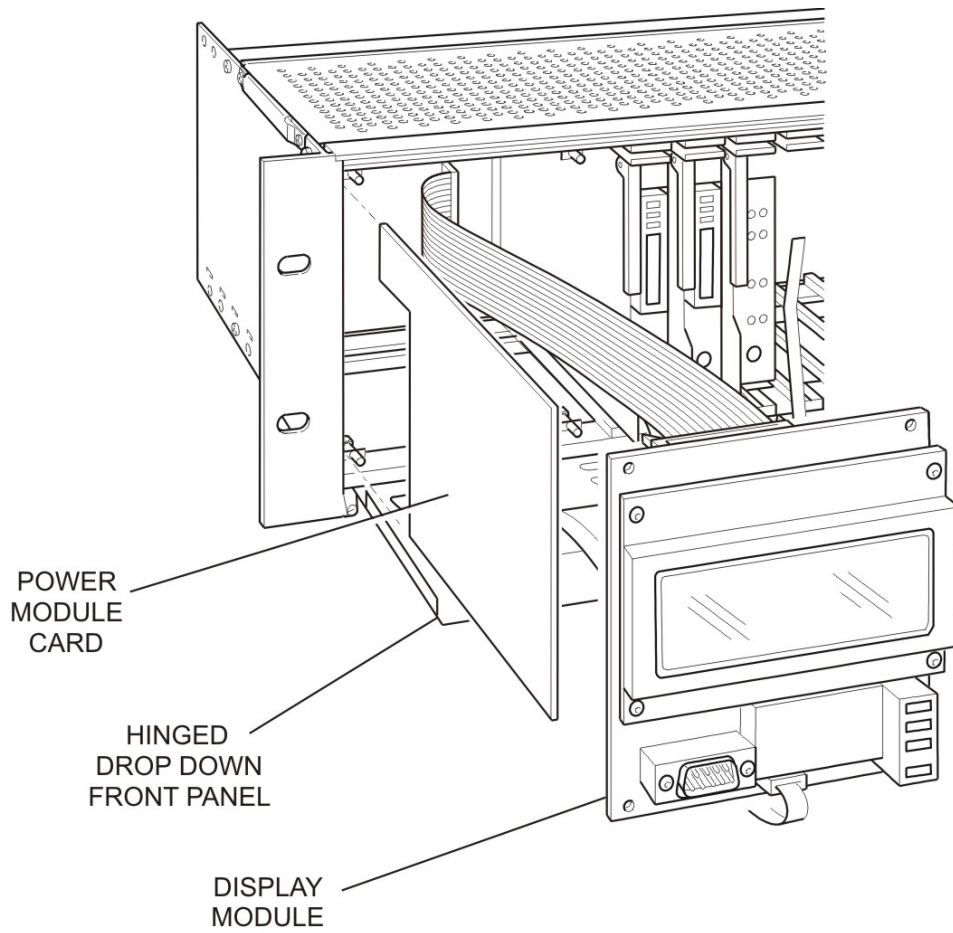

Figure 25: Power Module Mounting Detail

2.7.3.2 Power Supply Unit

One of two standard Power Supply Units may be supplied depending on the system configuration. Both are mounted in the control cabinet.

Crowcon Part No.	Input	Power	Output
E01546	100-120Vac 220-240Vac 50/60Hz Switch selectable	150W	27.6Vdc
E01547	100-260Vac 50/60Hz Auto-ranging	300W	27.6Vdc

Figure 26 details the mounting arrangements of these Power Supply Units.

HARDWARE

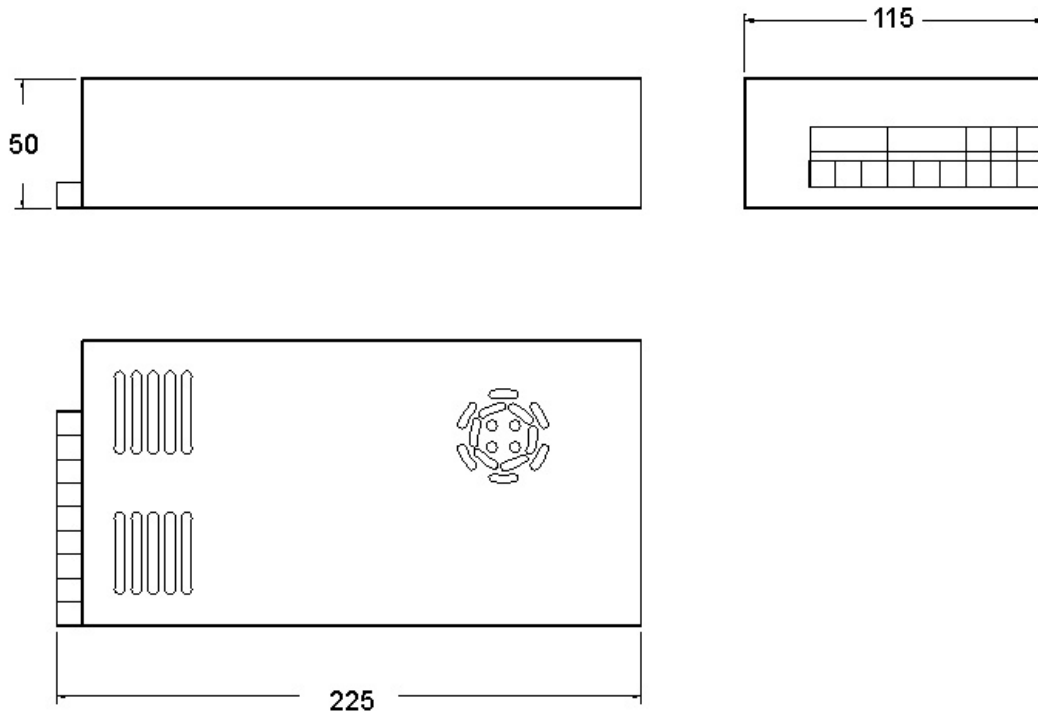

Figure 26 (a): 300W Power Supply Mounting Detail (mm)

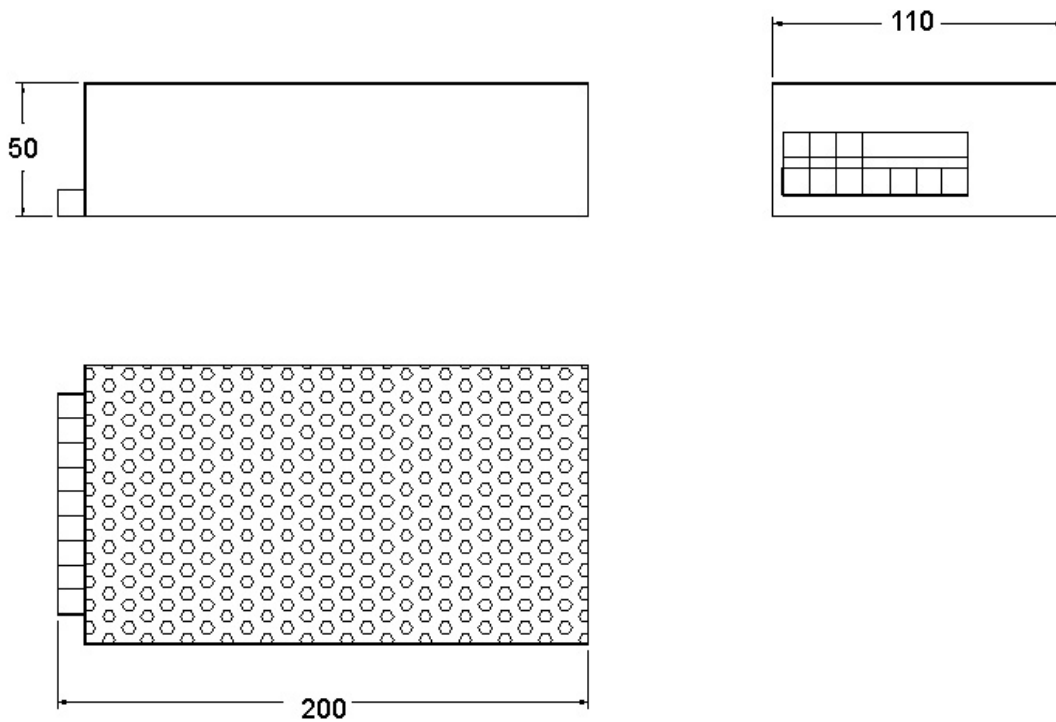

Figure 26 (b): 150W Power Supply Mounting Detail (mm)

2.7.3.3 Batteries

Figure 27 shows the overall dimensions of a 12V, 7Ah battery. Fixing details in the control cabinet vary from system to system.

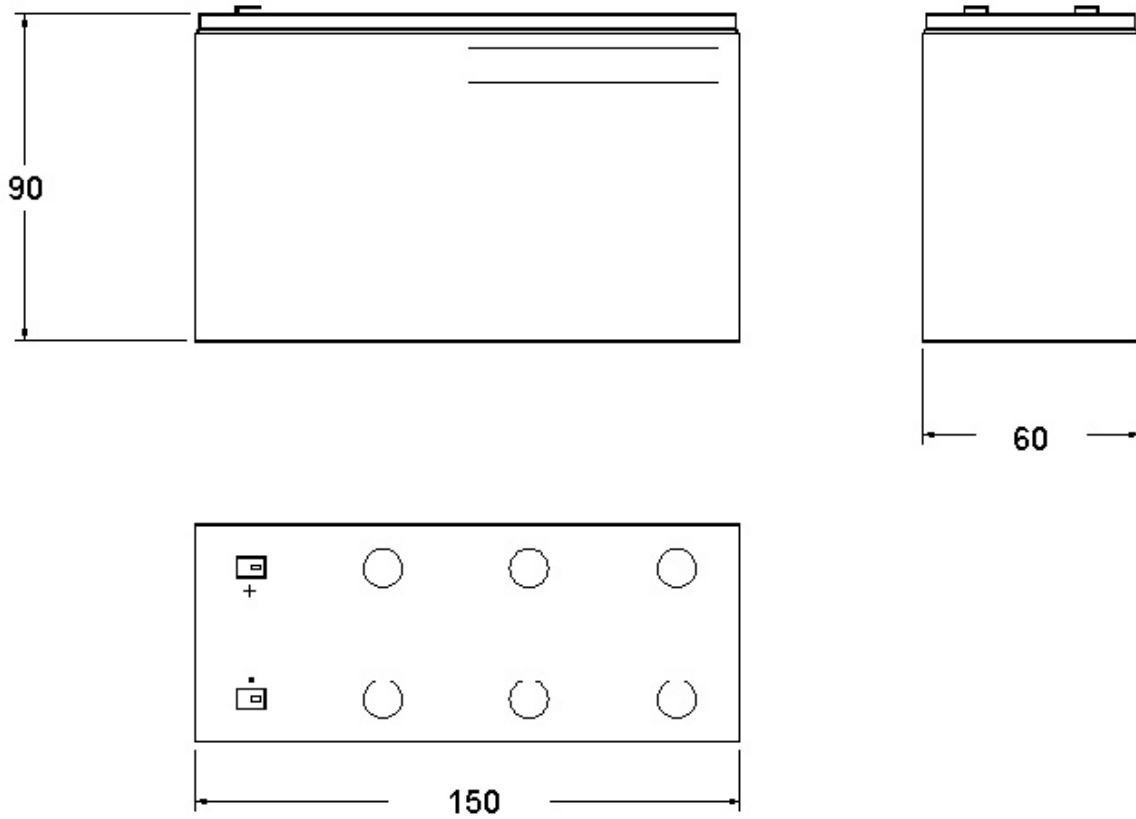

Figure 27: Battery Dimensions (mm)

HARDWARE

2.7.4 Electrical Connections

Figure 28 details the typical power supply connections for a Gasmonitor+ gas and fire control system.

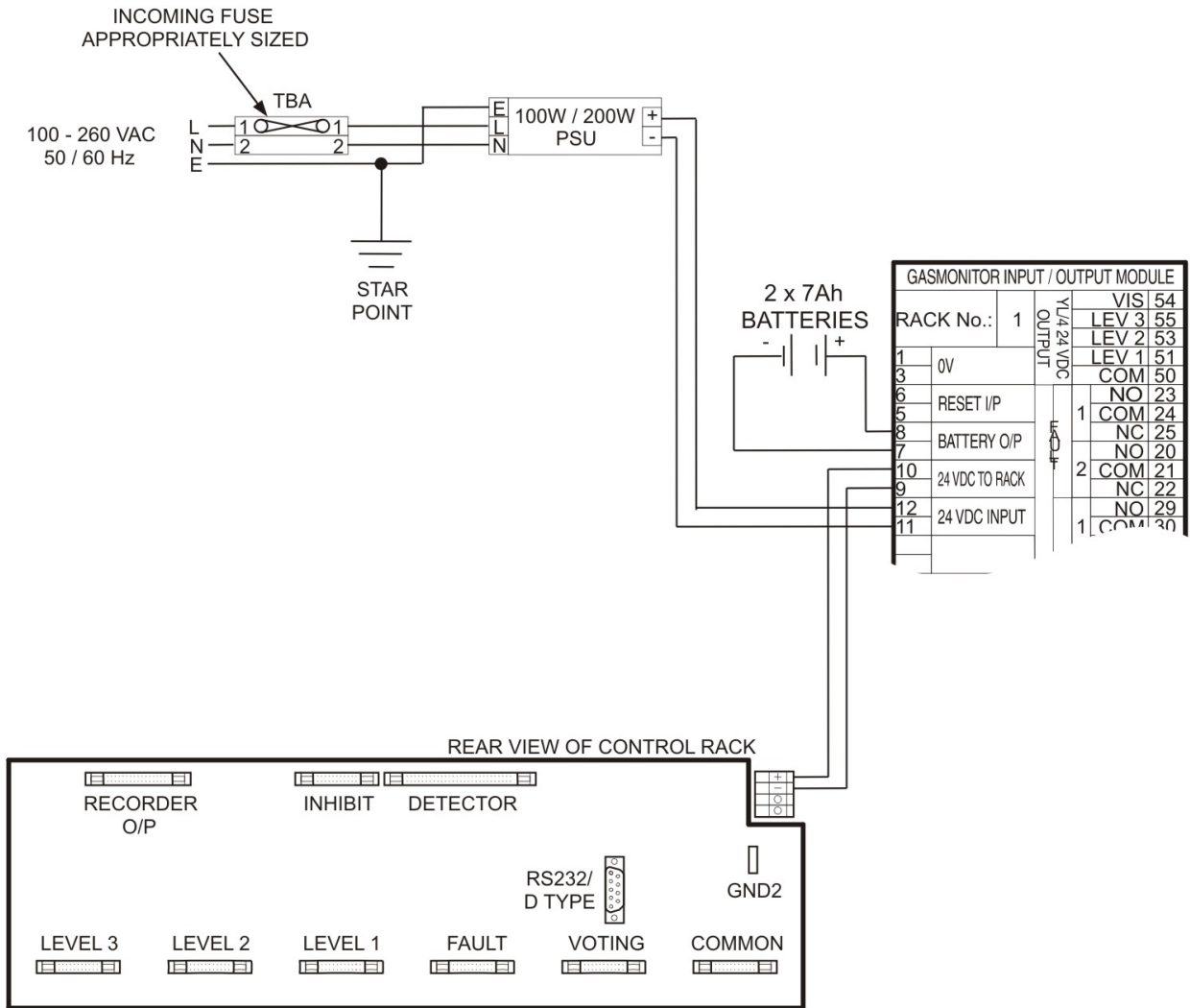

Figure 28: Power Distribution/Electrical Connections

HARDWARE

2.7.5 Calculation of Power Supply Requirements and Battery Backup

Each system is different. The following section provides a logical method of calculating power requirements and battery backup times. The calculation should be repeated for each specific system configuration.

2.7.5.1 Typical Power Consumption of Gasmonitor+ Modules

Table 1 below details the typical power consumption of Gasmonitor+ modules and some field equipment. The Quiescent Current quoted is the current drawn at 24Vdc (nominally) by the module with no alarms present. The Alarm Current is the current drawn with all alarms activated.

Module	Quiescent Current (mA)	Alarm Current (mA)
19" rack, Display Module and Input/Output Module	100mA	120mA
Universal Gas Input Card With Toxic Detector	45mA*	75mA*
Universal Gas Input Card With Flammable Detector	325mA*	355mA*
Twin Zone Fire Input Card	150mA (75mA per zone)	180mA (90mA per zone)
Relay Module	N/A	160mA (20mA per relay)
Audible Alarm	N/A	120mA
Visual Alarm	N/A	150mA

* Current consumption may vary depending on type of detector fitted. Contact Crowcon for further information.

2.7.5.2 Example Power/Battery Backup Calculation

A Gasmonitor+ system has been supplied to monitor eight points for flammable gas and raise an audible/visual alarm should gas be detected. What size power supply should be used? How long will the standard battery backup last should mains power fail?

Step 1 : Calculate maximum current consumption of the system

Module	Q'ty	Per Module		Total For System	
		Quiescent Current (mA)	Alarm Current (mA)	Quiescent Current (mA)	Alarm Current (mA)
19" rack, Display Module and Input/Output Module	1	100mA	120mA	100mA	120mA
Universal Gas Input Card With Flammable Detector	8	325mA	355mA	2600mA	2840mA
Audible Alarm	1	-	120mA	-	120mA
Visual Alarm	1	-	150mA	-	150mA
Total Current Consumption (mA)				2700mA	3230mA
Total Current Consumption (A)				2.7A	3.3A

Step 2 : Size the Power Supply Unit

When the mains supply is healthy the Power Supply Unit must be able to power the system in full alarm (3.3A) and trickle charge the batteries. 10% of the battery capacity should be allocated to the charging of the batteries.

Total current consumption of the system under full alarm = 3.3A

Additional current required to charge batteries = 0.7A (Assuming 7Ah batteries are used)

Total current to be supplied by Power Supply Unit = 4A @ 27.6Vdc

Assuming a power Supply Unit efficiency of 80% then the minimum power supply requirement is $(4 \times 27.6)/80\% = 138\text{W}$.

In this example the system would be fitted with a 300W Power Supply Unit.

Step 3 : Calculate the battery backup time

A standard system is fitted with 2 x 12Vdc, 7Ah batteries wired in series to provide 24Vdc, 7Ah worth of battery backup.

Note: Battery amp-hour ratings are specified with no more than 10% of maximum load applied i.e. a 7Ah battery will last for 10hours @ 700mA. As more current is drawn so the capacity is de-rated. Typical de-rating factors are:

	% of maximum	de-rating factor
$\leq 10\%$	1	
10% - 30%	0.75	
30% - 100%	0.58	

The backup time should no alarms occur = $7\text{Ah}/2.7\text{A} * 0.58 = 1 \text{ hrs, } 30 \text{ mins}$

The backup time under full alarm = $7\text{Ah}/3.3\text{A} * 0.58 = 1 \text{ hrs, } 13 \text{ mins}$

The above calculations are based on a worst case scenario, as it is unlikely that all channels will go into full alarm at the same time.

3 FIELD DEVICES

3.1 General

Prior to installing field devices users should be familiar with the operation and configuration of Gasmonitor+ using the Display Module pushbuttons and SetGmon software supplied. Detailed operating instructions are given in Appendices A and B.

Crowcon recommend that the installation of a Gasmonitor+ system is carried out by people with experience of installing electrical equipment in potentially hazardous atmospheres.

Local regulations and installation practices vary from country to country. The relevant codes of practice in the country concerned should be observed. Further advice is available from Crowcon if required.

Equipment may be mounted in potentially explosive atmospheres. Check that the equipment to be installed is suitable for the area classification. Site procedures should be followed before attempting installation or maintenance of any field device.

Gasmonitor+ may be configured to shutdown plant automatically. Outputs should be isolated so as to prevent spurious trips wherever possible. If in doubt seek advice from site personnel before proceeding.

Always read the Installation, Operating and Maintenance Instructions supplied with the field device before attempting installation or maintenance.

Dummy loads can be fitted in place of detector heads for test purposes. See section 3.3.3.6.

3.2 Gas Detector Installation and Operation

3.2.1 Approved Gas Detectors

Crowcon manufacture a wide range of flammable and toxic gas detectors. The Gasmonitor+ Universal Gas Input Card is able to control all detectors manufactured by Crowcon.

The following list details detectors currently manufactured by Crowcon for use with Gasmonitor+.

Product Name	Type of Detector	Typical Range/Gas
FLAMMABLE GAS DETECTORS		
Flamgard EXE	Pellistor/catalytic bead. 3 wire mV bridge output. Increased safety.	0-100% LEL Most flammable gases.
Xgard Type 3	Pellistor/catalytic bead. 3 wire mV bridge output. Flameproof.	0-100% LEL. Most flammable gases.
Xgard Type 4	Pellistor/catalytic bead. 3 wire mV bridge output. Flameproof.	0-100% LEL. Most flammable gases.
Xgard Type 5	Pellistor/catalytic bead. 3 wire sink or source 4-20mA output. Flameproof.	0-100% LEL. Most flammable gases.
Flamgard Plus	Pellistor/catalytic bead. 3 wire sink or source 4-20mA. output. Flameproof.	0-100% LEL. Most flammable gases
Xgard IR	Infrared.. 3 wire sink or source 4-20mA	0-100% LEL Most hydrocarbon gases. output.

Product Name	Type of Detector	Typical Range/Gas
	Flameproof.	
Nimbus	Infrared.. 3 wire sink and source 4-20mA Flameproof.	0-100% LEL C1 to C5 hydrocarbons, output. ethylene and LPG.
TOXIC GAS DETECTORS		
TXgard IS+	Electrochemical. 2 wire 4-20mA loop powered. Intrinsically safe.	Various ranges. Most toxic gases and oxygen.
Xgard Type 2	Electrochemical. 2 wire 4-20mA loop powered. Flameproof.	Various ranges. Oxygen, carbon monoxide, ammonia, sulphur dioxide and hydrogen sulphide only.
Xgard Type 1	Electrochemical 2-wire 4-20 mA loop powered Intrinsically safe	Various ranges Most toxic gases and oxygen
TXgard Plus	Electrochemical. 3 wire sink or source 4-20mA output. Flameproof.	Various ranges. Oxygen, carbon monoxide and hydrogen sulphide only.
OTHER		
TCgard	Thermal conductivity. 3 wire sink or source 4-20mA output. Flameproof.	0-100% vv. Suitable binary gases only.

Detectors not listed may still be used with Gasmonitor+. For further details contact Crowcon.

3.2.2 Detector Location

There are no rules which dictate the siting and location of detectors, however, considerable guidance is available from BS EN 50073:1999 'Guide for Selection, Installation, Use and Maintenance of Apparatus for the Detection and Measurement of Combustible Gases or Oxygen'. Similar international codes of practice may be used where applicable. In addition certain regulatory bodies publish specifications giving minimum gas detection requirements for specific applications.

The detector should be mounted where the gas is most likely to be present. The following points should be noted when locating gas detectors:

To detect gases which are lighter than air, e.g., methane, detectors should be mounted at high level and Crowcon recommend the use of a Collector Cone.

To detect heavier than air gases, e.g., butane, detectors should be mounted at low level. The use of additional sampling equipment such as the 87ESU may improve the detection rate of heavier than air gases. Contact Crowcon for details.

To detect gases with similar weight to air, e.g., hydrogen sulphide mount the detector at normal breathing height.

Mounting of oxygen detectors requires knowledge of the gas displacing the oxygen. E.g., carbon dioxide is heavier than air and will displace oxygen at a low level. Under these circumstances oxygen detectors should be placed at low level.

When locating detectors consider the possible damage caused by natural events, e.g., rain or flooding. For detectors mounted outdoors Crowcon recommend the use of a Weatherproof Caps and Spray Deflectors.

Consider ease of access for functional testing and servicing.

Consider how the escaping gas may behave due to natural or forced air currents. Mount detectors in ventilation ducts if appropriate.

Consider the process conditions. Gases that are normally heavier than air, but released from a process line that is at an elevated temperature and/or under pressure may rise rather than fall.

The placement of the sensors should be determined following the advice of experts having specialist knowledge of gas dispersion, experts having a knowledge of the process plant system and equipment involved, safety and engineering personnel. **The agreement reached on the locations of sensors should be recorded.** Crowcon would be pleased to assist in the selection and siting of gas detectors.

3.2.3 Set-up and Operation: 3 wire mV bridge devices

3.2.3.1 General

These detectors are all pellistor/catalytic bead type and operate on the Wheatstone bridge principle. The detectors are 3 wire and provide a mV output proportional to the gas concentration. For details on each type of gas detector please refer to the relevant Installation, Operating and Maintenance Instructions provided with each detector.

These detectors are simple devices, i.e., these detectors must be used with a dedicated control card to supply power and process the signal before raising alarms should gas be detected.

3.2.3.2 Cabling Requirement

Cabling to the detector must be in accordance with the recognised standards of the appropriate authority in the country concerned and meet the electrical requirements of the detector.

Crowcon recommend the use of steel wire armoured (SWA) cable and suitable explosion proof glands must be used.

Alternative cabling techniques, such as steel conduit, may be acceptable provided appropriate standards are met.

The maximum acceptable loop resistance is 36 Ohms. The following table summarises the maximum cable length allowed for up to 2.5mm² cross sectional area (c.s.a.) cable.

c.s.a. (mm²)¹	Typical Resistance per Km of Cable (Ohms)	Typical Loop Resistance per Km of Cable (Ohms)	Maximum Cable Length (m)²
0.5 (20)	39.0	78.0	400 (1312)
1.0 (17)	18.1	36.2	900 (2952)
1.5 (15)	12.1	24.2	1400 (4592)
2.5 (13)	8.0	16.0	2000 (6560)

Notes:

¹ *Approximate c.s.a. in awg given in brackets.*

² *Approximate distance in feet given in brackets.*

3.2.4 Earthing

The junction box and cable armour must be earthed at either the detector or control panel to limit the effects of radio frequency interference. It is good practice to provide the earth connection at the safe area **only**, so as to avoid earth loops.

3.2.5 Universal Gas Input Card Jumper Settings

For details of all jumper settings refer to Hardware, Universal Gas Input Card Jumper Settings, section 2.3.5.

As standard the jumper settings required are:

Link	Position
LK 1	None
LK 2	E, I, K, E-F, I-J, K-L
LK 3	STD
LK 4	PELL
LK 5	REG
LK 6 and 7	24V C/C

Alternative LK 2 and LK 3 settings may be required. Refer to Hardware, Universal Gas Input Card Jumper Settings, section 2.3.5.

3.2.6 Electrical Connections

Figure 29 details typical electrical connections to be made to the Input/Output Module.

Note:

Allocation of detector type to channel is indicative only. Any detector type can be connected to any channel.

For further termination detail refer to Figure 17.

NOTE : EACH DETECTOR EARTHED
IN SAME MANNER AS
FLAMGARD EXE

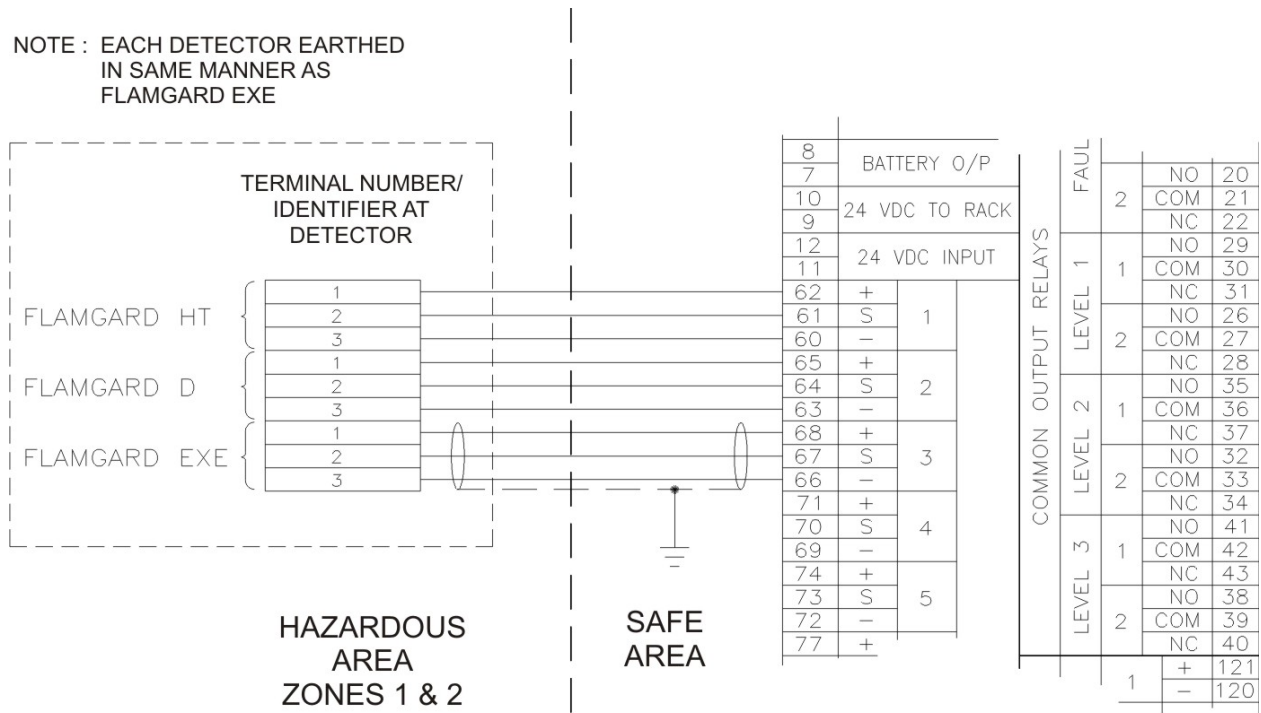

GASMONITOR UNIVERSAL GAS
INPUT CARD / IO MODULE
REFER TO DIAGRAM 17 FOR
TERMINAL NUMBERS O
INDIVIDUAL CHANNELS

Figure 29: Gasmonitor+ 3-wire mV bridge type gas detectors

FIELD DEVICES

3.2.7 Setting to Work

Setting to work requires that the system has been turned on and allowed to stabilise for at least 2 hours.

Each pellistor/catalytic bead type flammable gas detector requires the correct head voltage to be applied across terminals 1 and 3 (Figure 29). The detector Installation, Operation and Maintenance Instructions will detail the correct head voltage for the type of detector installed.

It is assumed that the detector has been powered and allowed to stabilise for at least 2 hours.

To set the head voltage:

1. Inhibit the input card to be adjusted by pressing the INHIBIT button on the input card and the RESET button on the Display Module simultaneously.
2. Open the drop down front panel of the control rack by loosening the three fixing screws (see Figure 4).
3. Using the four pushbuttons on the Display Module select SET FLAMMABLE HEAD on the menu system (see Appendix A).
4. Using the four pushbuttons on the Display Module select the channel to be set up.
5. At this point one LED on the bar graph of the input card to be set up may or may not illuminate.
6. Measure the head volts at the detector across terminals 1 and 3 using a digital voltmeter (DVM).
7. Using an instrument screw driver adjust the HEAD CURRENT potentiometer (see Figure 11) on the input card until the DVM measures the correct head voltage at the detector.
8. Using the instrument screw driver adjust the HEAD BALANCE potentiometer (see Figure 11) on the input card until the LED on the bar graph is positioned centrally. When centred the LED will turn off.
9. Close the drop down front panel and return the Display Module and input card to normal operation using the front panel pushbuttons.

10. The input card and remote gas detector are now set up for correct operation and are ready to be calibrated.

3.2.7.1 Calibration

Calibration may be performed via the four pushbuttons or the SetGmon software provided. Where single channels require calibration Crowcon recommend the following procedure. Where many channels are to be calibrated Crowcon recommend the use of SetGmon (see Appendix B).

Calibration gas and accessories are available from Crowcon.

When calibrating an input card and detector for the first time Crowcon recommend that two persons be used, one at the detector and the other at the control panel. When gas is applied to the detector in the field the person at the control panel can check that the detector is connected to the correct input card by observing the gas reading or bar graph on the front panel.

Once the link between the detector and input card has been proved one person can carry out future calibrations and routine functional testing (see Routine Functional Testing, section 3.2.7.2).

To calibrate the detector:

1. Inhibit the input card of the detector to be calibrated by pressing the INHIBIT button on the input card and the RESET button on the Display Module simultaneously.
2. Ensure that the detector to be calibrated is in clean air. It may be necessary to apply compressed air to the detector at a flow rate of 0.5 litres per minute if flammable gas is permanently present in the area where the detector is mounted.
3. Using the four pushbuttons on the Display Module select ZERO?
4. Using the four pushbuttons on the Display Module select the channel to be zeroed.
5. Zero the channel by following the commands on the Display Module. On completion the message 'Zero successful' is displayed.
6. Using the four pushbuttons on the Display Module select CALIBRATE?
7. Using the four pushbuttons on the Display Module select the channel to be calibrated.

8. Apply calibration gas to the detector (typically 50% LEL flammable gas in air) at a flow rate of 0.5 litres per minute.
9. Allow the gas level reading on the Display Module to stabilise and then adjust the displayed value by pressing the UP and DOWN pushbuttons on the Display Module until the displayed value corresponds to the calibration gas applied.
10. Press the YES button on the Display Module to calibrate the channel.
11. The detector and input card are now configured and calibrated correctly.
12. Return the Display Module and input card to normal operation using the pushbuttons mounted on the front panel.

3.2.7.2 Routine Functional Testing

Crowcon recommend that detectors be routinely checked to ensure correct calibration and operation. This should be carried out at least every 6 months, however, site procedures may stipulate more frequent checks.

The following routine is supplied for information only:

1. Inhibit all input cards in any single control rack by pressing the INHIBIT button on each input card and the RESET button on the Display Module simultaneously.
2. Ensure that the detectors to be checked are in clean air and re-zero as necessary.
3. Using the four pushbuttons on the Display Module select HOLDALL CAL?
4. Pressing the YES button instructs the Display Module to log the peak gas reading from each input card. The message 'Collecting Peaks' is displayed during this operation.
5. Apply calibration gas to each detector to be checked in turn and return to the control panel.
6. Pressing the DONE button on the Display Module displays the message 'ADJ Ch1 > XXX?' where XXX is the name given to that channel.
7. Upon pressing the YES button on the Display Module the user may adjust the reading by pressing them UP and DOWN buttons until the reading displayed matches the calibration gas used.
8. Press the YES button on the Display Module to calibrate the channel.
9. This can be repeated for each channel in the control rack.

10. Once the system has been fully checked return the Display Module and input cards to normal operation using the pushbuttons mounted on the front panel.

3.2.8 Set-up and Operation: 3 wire 4-20 mA devices

3.2.8.1 General

These detectors operate on various different principles including pellistor/catalytic bead, electrochemical and infrared.

Each detector includes a local amplifier which accepts power from the Universal Gas Input Card and provides a 4-20 mA output proportional to the gas concentration at the detector.

The following instructions assume that each detector has been configured in a 3 wire, 4-20 mA source configuration.

These detectors must be calibrated independently of the Gasmonitor+ control system. For details on each type of gas detector please refer to the relevant Installation, Operating and Maintenance Instructions provided with each detector.

3.2.8.2 Cabling Requirement

Cabling to the detector must be in accordance with the recognised standards of the appropriate authority in the country concerned and meet the electrical requirements of the detector.

Crowcon recommend the use of steel wire armoured (SWA) cable and suitable explosion proof glands must be used.

Alternative cabling techniques, such as steel conduit, may be acceptable provided appropriate standards are met.

The minimum acceptable supply voltage measured at the detector and the maximum current drawn by that detector is different for each device. Gasmonitor+ supplies a guaranteed minimum supply voltage of 22 Vdc. Please refer to the relevant Installation, Operating and Maintenance Instructions

provided with each detector to calculate the maximum cable distances allowed for different cable types.

3.2.8.3 Earthing

The junction box and cable armour must be earthed at either the detector or control panel to limit the effects of radio frequency interference. It is good practice to provide the earth connection at the safe area **only**, so as to avoid earth loops.

3.2.8.4 Universal Gas Input Card Jumper Settings

For details of all jumper settings refer to Hardware, Universal Gas Input Card Jumper Settings, section 2.3.5.

As standard the jumper settings required are:

Link	Position
LK 1	B, D, B-C, D-E
LK 2	E, I, K, E-F, I-J, K-L
LK 3	STD
LK 4	4-20
LK 5	24V
LK 6 and 7	24V C/C

Alternative LK 2 and LK 3 settings may be required. Refer to Hardware, Universal Gas Input Card Jumper Settings, section 2.3.5.

3.2.8.5 Electrical Connections

Figure 30 details typical electrical connections to be made to the Input/Output Module.

Note:

Allocation of detector type to channel is indicative only. Any detector type can be connected to any channel.

For further termination detail refer to Figure 17.

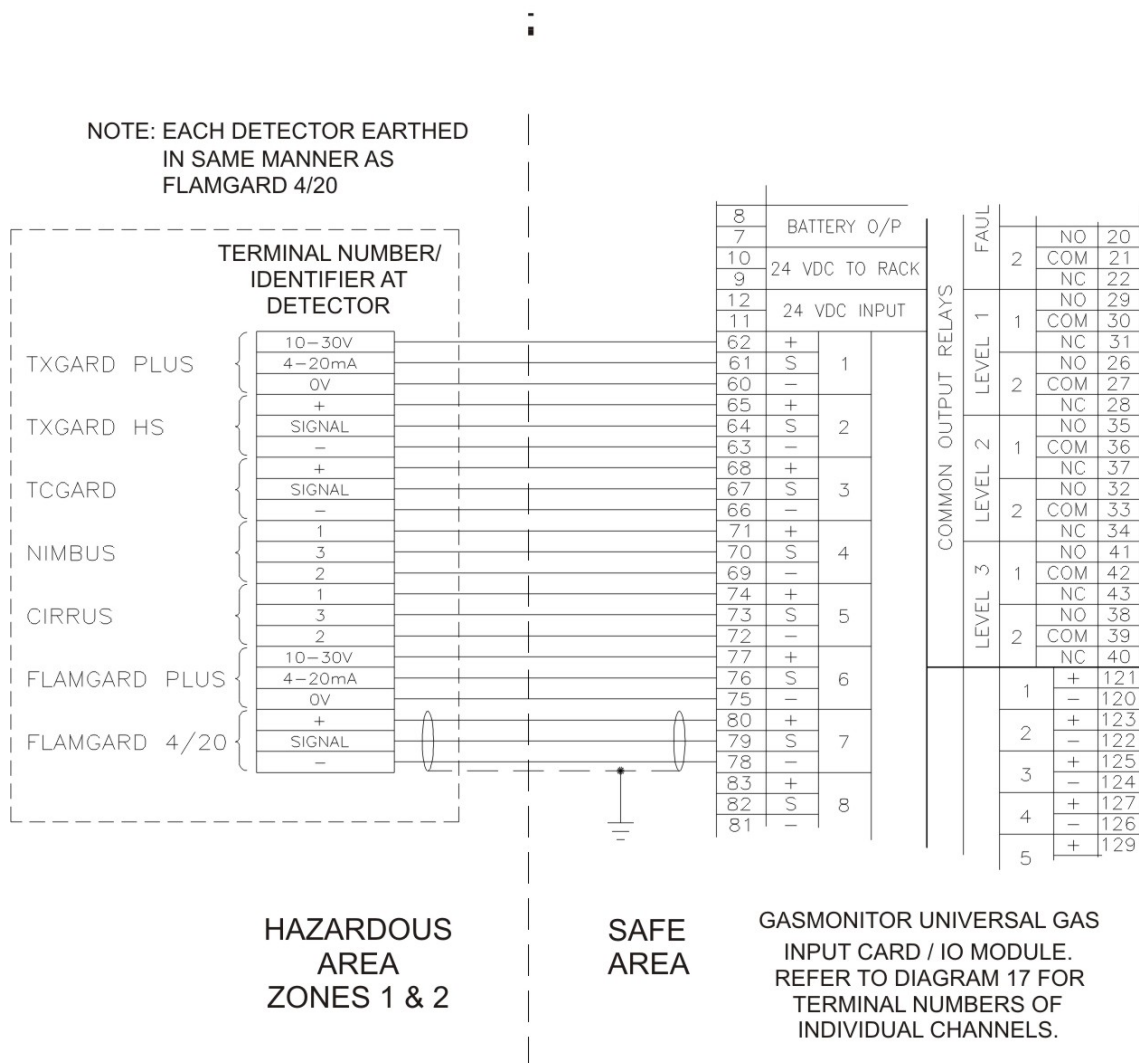

Figure 30: Gasmonitor+ to 3-wire 4-20 mA type detectors

3.2.8.6 Setting to Work

The detector must be calibrated before calibration of the associated input card. For calibration details of each detector please refer to the relevant Installation, Operating and Maintenance Instructions provided with each detector.

3.2.8.7 Calibration

Calibration of the input card may be performed via the four pushbuttons or the SetGmon software provided. Where single channels require calibration Crowcon recommend the following procedure. Where many channels are to be calibrated Crowcon recommend the use of SetGmon (see Appendix B).

Calibration gas and accessories are available from Crowcon.

When calibrating an input card and detector for the first time Crowcon recommend that two persons be used, one at the detector and the other at the control panel. When gas is applied to the detector in the field the person at the control panel can check that the detector is connected to the correct input card by observing the gas reading or bar graph on the front panel.

Once the link between the detector and input card has been proved one person can carry out future calibrations and routine functional testing (see section 3.2.8.8).

To calibrate the input card for use with a 4-20mA type detector:

1. Inhibit the input card of the channel to be calibrated by pressing the INHIBIT button on the input card and the RESET button on the Display Module simultaneously.
2. Ensure that the associated detector is reading zero gas level, i.e., output is 4 mA.
3. Using the four pushbuttons on the Display Module select ZERO?
4. Using the four pushbuttons on the Display Module select the channel to be zeroed.
5. Zero the channel by following the commands on the Display Module. On completion the message 'Zero successful' is displayed.
6. Using the four pushbuttons on the Display Module select CALIBRATE?

7. Using the four pushbuttons on the Display Module select the channel to be calibrated.
8. Apply calibration gas to the detector (normally half scale).
9. Allow the gas level reading on the Display Module to stabilise and then adjust the displayed value by pressing the UP and DOWN pushbuttons on the Display Module until the displayed value corresponds to the calibration gas applied.
10. Press the YES button on the Display Module to calibrate the channel.
11. The detector and input card are now configured and calibrated correctly.
12. Return the Display Module and input card to normal operation using the pushbuttons mounted on the front panel.

3.2.8.8 Routine Functional Testing

Crowcon recommend that detectors be routinely checked to ensure correct calibration and operation. This should be carried out at least every 6 months, however, site procedures may stipulate more frequent checks.

One person may check a detector with a local amplifier at the detector and no adjustment at the control panel should be required.

Depending on the detector functionality it may be necessary to inhibit the associated input card before attempting routine functional testing of the detector.

For detailed instructions on the routine functional testing of the detectors please refer to the relevant Installation, Operating and Maintenance Instructions provided with each detector.

The calibration of the input card should be checked annually as a minimum. To check the input cards calibration:

1. Inhibit all input cards in any single control rack by pressing the INHIBIT button on each input card and the RESET button on the Display Module simultaneously.
2. Ensure that the detectors are reading zero gas, i.e., detector output set to 4mA.
3. Using the four pushbuttons on the Display Module re-zero each input card as necessary.

4. Using the four pushbuttons on the Display Module select HOLDALL CAL?
5. Pressing the YES button instructs the Display Module to log the peak gas reading from each input card. The message 'Collecting Peaks' is displayed during this operation.
6. Apply calibration gas to each detector in turn and return to the control panel.
7. Pressing the DONE button on the Display Module displays the message 'ADJ Ch1 > XXX?' where XXX is the name given to that channel.
8. Upon pressing the YES button on the Display Module the user may adjust the reading by pressing them UP and DOWN buttons until the reading displayed matches the calibration gas used.
9. Press the YES button on the Display Module to calibrate the channel.
10. This can be repeated for each channel in the control rack.
11. Once the system has been fully checked return the Display Module and input cards to normal operation using the pushbuttons mounted on the front panel.

3.2.9 Set-up and Operation: 2 wire 4-20 mA intrinsically safe devices

3.2.9.1 General

These devices may be fitted with various electrochemical sensors to monitor toxic gases and oxygen.

Each detector is 4-20mA loop powered and includes a local amplifier. The 420 mA output is proportional to the gas concentration at the detector. Such devices are sink only.

The detectors must be calibrated independently of the Gasmonitor+ control system. For details on each type of gas detector please refer to the relevant Installation, Operating and Maintenance Instructions provided with each detector.

The device must be used with a suitable line isolator, i.e., Zener barrier or galvanic isolator, when used in a hazardous atmosphere.

3.2.9.2 Cabling Requirement

Cabling to the detector must be in accordance with the recognised standards of the appropriate authority in the country concerned and meet the electrical requirements of the detector.

Crowcon recommend the use of twisted pair cable with overall screen and sheath. Suitable weatherproof glands must be used.

Alternative cabling techniques, such as steel conduit, may be acceptable provided appropriate standards are met.

The maximum cable distance allowed is dependent upon the installation, i.e., whether Zener barriers or galvanic isolators are required or not.

The following table summarises the maximum theoretical cable distance for different installations.

c.s.a. (mm ²)	Typical Loop Resistance per Km of Cable (Ohms)	Maximum Cable Length		
		No Barrier	Zener Barrier	Galvanic Isolator
0.5	78.0	2.9 Km	1.0 Km	2.9 Km
1.0	36.2	6.3 Km	2.2 Km	6.3 Km
1.5	24.2	9.5 Km	3.3 Km	9.5 Km
2.5	16.0	14.3 Km	5.0 Km	14.3 Km

This table was calculated given:

The maximum loop resistance allowed by Gasmonitor+ = 820 Ohms

Input card sense resistor = 250 Ohms

Minimum acceptable supply voltage at detector = 10 V dc

Maximum current drawn by detector = 25 mA

Inherent loop resistance of Zener barrier = 300 Ohms

3.2.9.3 Earthing

It is essential to observe the correct earthing arrangement when using intrinsically safe gas detectors.

When the detector is mounted in a safe area (no line isolators), or is used with a galvanic isolator, the junction box and cable screen must be earthed at either the detector or control panel to limit the effects of radio frequency interference. It is good practice to provide the earth connection at the safe area **only**, so as to avoid earth loops.

When the detector is used with a Zener barrier a certified IS earth is required at the Zener barrier. The junction box and cable screen must be earthed at the IS

earth to meet intrinsic safety requirements and to limit the effects of radio frequency interference.

When Zener barriers are used the link GND2 must be removed from the motherboard of the 19" control rack.

3.2.9.4 Universal Gas Input Card Jumper Settings

For details of all jumper settings refer to Hardware, Universal Gas Input Card Jumper Settings, section 2.3.5.

The following table summarises the link settings required when using 2 wire 4-20 mA devices with a Universal Gas Input Card.

Link	Link Position	
	No Barrier , Dual Barrier or Zener Barrier	Galvanic Isolator
LK 1	A, C, A-B, C-D	B, D, B-C, D-E
LK 2	E, I , K, E-F, I-J, K-L	E, I and K
LK 3	None	None
LK 4	4-20	4-20
LK 5	24V	24V
LK 6 and 7	24V C/C	24V C/C

Alternative LK 2 settings may be required. Refer to Hardware, Universal Gas Input Card Jumper Settings, section 2.3.5.

3.2.9.5 Electrical Connections

Figure 31 details typical electrical connections to be made to the Input/Output Module for different installation methods.

Note:

Allocation of detector type to channel is indicative only. Any detector type can be connected to any channel.

For further termination detail refer to Figure 17.

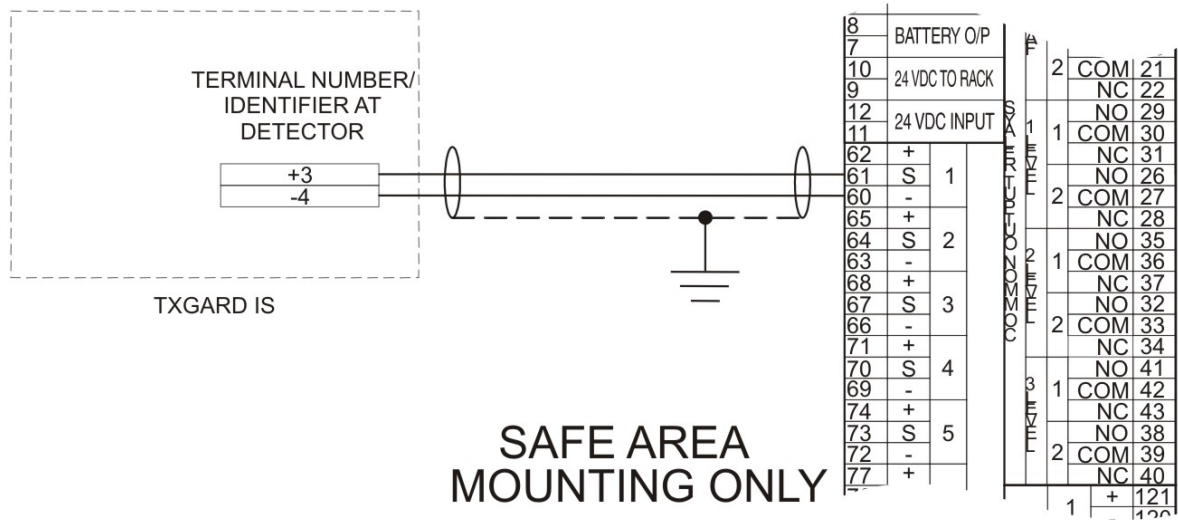

GASMONITOR UNIVERSAL GAS INPUT CARD / IO MODULE. REFER TO DIAGRAM 17 FOR TERMINAL NUMBERS OF INDIVIDUAL CHANNELS.

FIELD DEVICES

Figure 31 (a): Gasmonitor+ to 2-wire type current sink (loop powered) detector

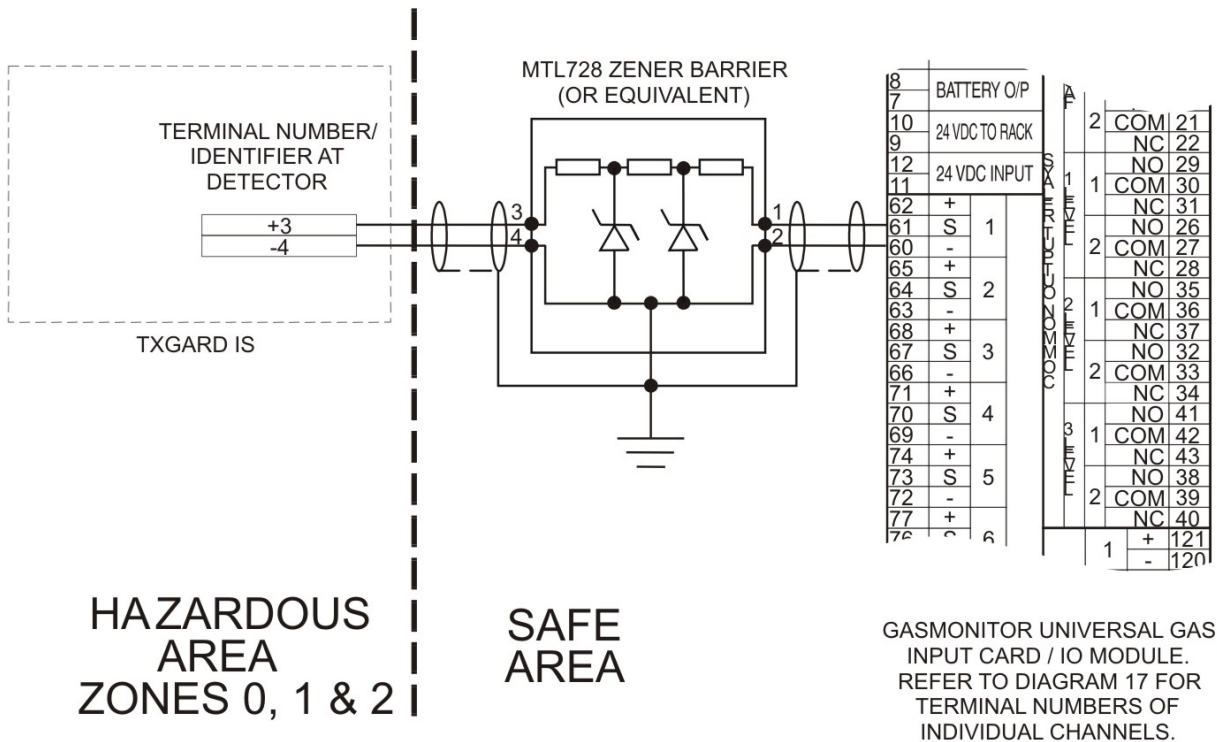

Figure 31 (b): Gasmonitor+ to 2-wire I.S. type detector via Zener Barrier Typical Wiring Detail

FFIELD DEVICES

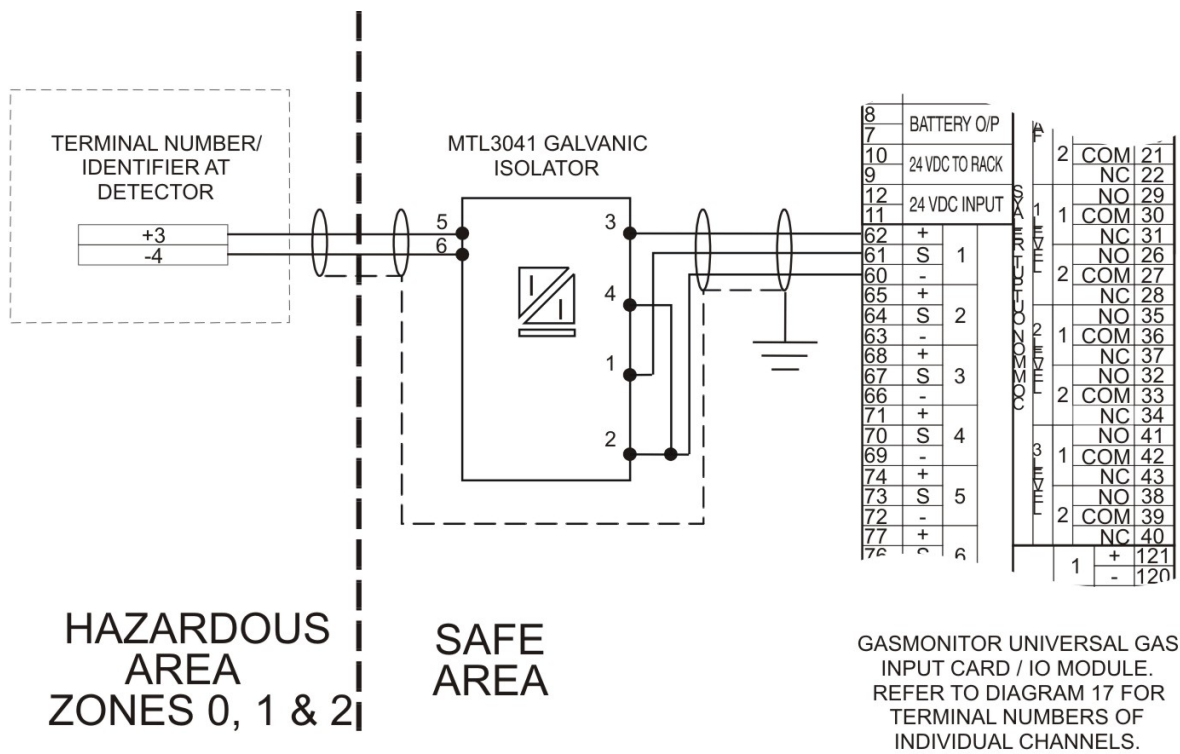

Figure 31 (c): Gasmonitor+ to 2-wire I.S. type detector via MTL 3041 Galvanic Isolator Typical Wiring Detail

FIELD DEVICES

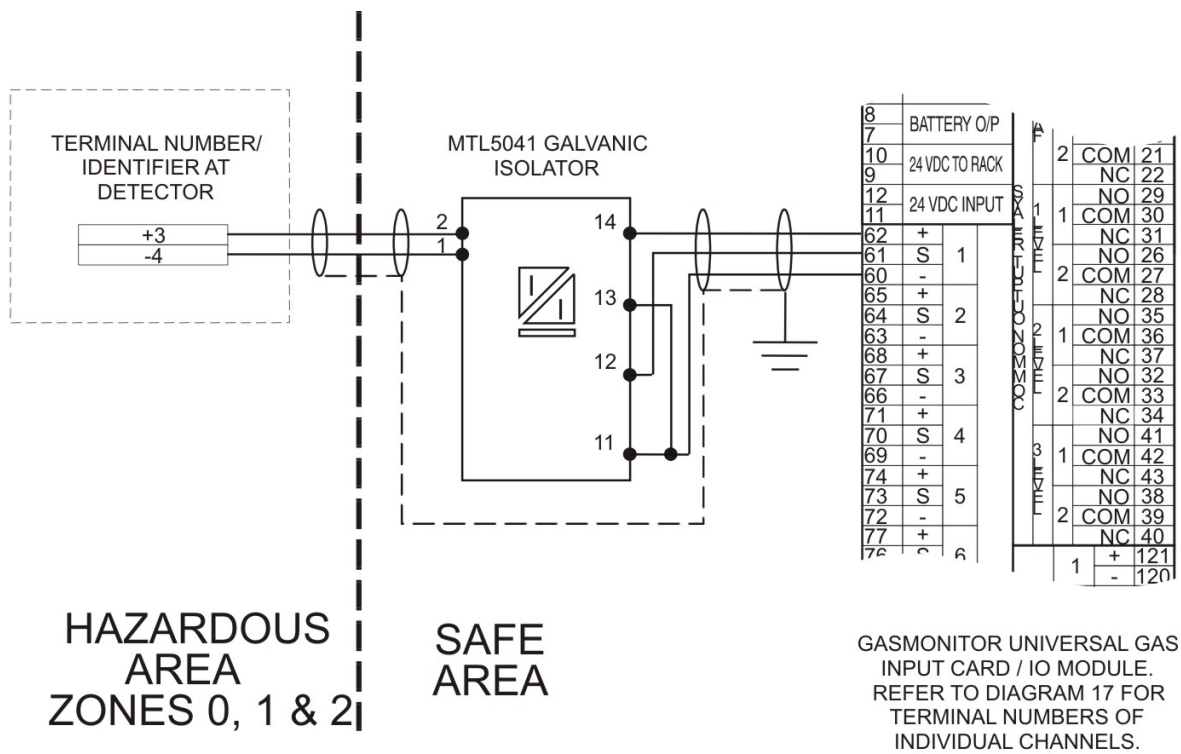

Figure 31 (d): Gasmonitor+ to 2-wire I.S. type detector MTL 5041 Galvanic Isolator Typical Wiring Detail

FFIELD DEVICES

3.2.9.6 *Setting to Work*

The detector must be calibrated before calibration of the associated input card. For calibration details of each detector please refer to the Installation, Operating and Maintenance Instructions provided with each detector.

3.2.9.7 *Calibration*

Calibration of the input card may be performed via the four pushbuttons or the SetGmon software provided. Where single channels require calibration Crowcon recommend the following procedure. Where many channels are to be calibrated Crowcon recommend the use of SetGmon (see Appendix B).

Calibration gas and accessories are available from Crowcon.

When calibrating an input card and detector for the first time Crowcon recommend that two persons be used, one at the detector and the other at the control panel. When gas is applied to the detector in the field the person at the control panel can check that the detector is connected to the correct input card by observing the gas reading or bar graph on the front panel.

Once the link between the detector and input card has been proved one person can carry out future calibrations and routine functional testing (see Routine Functional Testing, section 3.2.9.8).

To calibrate the input card for use with 2 wire 4-20 mA detector:

1. Inhibit the input card of the channel to be calibrated by pressing the INHIBIT button on the input card and the RESET button on the Display Module simultaneously.
2. Ensure that the associated detector is reading zero gas level, i.e., output is 4 mA. For an oxygen sensor, the sensor must be disconnected from the current amplifier at the detector head while this reading is made.
3. Using the four pushbuttons on the Display Module select ZERO?
4. Using the four pushbuttons on the Display Module select the channel to be zeroed.
5. Zero the channel by following the commands on the Display Module. On completion the message 'Zero successful' is displayed.

6. Using the four pushbuttons on the Display Module select CALIBRATE?
7. Using the four pushbuttons on the Display Module select the channel to be calibrated.
8. Apply calibration gas to the detector (normally half scale).
9. Allow the gas level reading on the Display Module to stabilise and then adjust the displayed value by pressing the UP and DOWN pushbuttons on the Display Module until the displayed value corresponds to the calibration gas applied.
10. Press the YES button on the Display Module to calibrate the channel.
11. The detector and input card are now configured and calibrated correctly.

Return the Display Module and input card to normal operation using the pushbuttons mounted on the front panel.

3.2.9.8 Routine Functional Testing

Crowcon recommend that detectors be routinely checked to ensure correct calibration and operation. This should be carried out at least every 6 months, however, site procedures may stipulate more frequent checks.

Only one person is required to check a detector fitted with a local amplifier and no adjustment at the control panel should be required.

Depending on the detector functionality it may be necessary to inhibit the associated input card before attempting routine functional testing of the detector.

For detailed instructions on the routine functional testing of the detectors please refer to the relevant Installation, Operating and Maintenance Instructions provided with each detector.

The calibration of the input card should be checked annually as a minimum. To check the input cards calibration:

1. Inhibit all input cards in any single control rack by pressing the INHIBIT button on each input card and the RESET button on the Display Module simultaneously.
2. Ensure that the detectors are reading zero gas, i.e., detector output set to 4 mA.

3. Using the four pushbuttons on the Display Module re-zero each input card as necessary.
4. Using the four pushbuttons on the Display Module select HOLDALL CAL?
5. Pressing the YES button instructs the Display Module to log the peak gas reading from each input card. The message 'Collecting Peaks' is displayed during this operation.
6. Apply calibration gas to each detector in turn and return to the control panel.
7. Pressing the DONE button on the Display Module displays the message 'ADJ Ch1 > XXX?' where XXX is the name given to that channel.
8. Upon pressing the YES button on the Display Module the user may adjust the reading by pressing them UP and DOWN buttons until the reading displayed matches the calibration gas used.
9. Press the YES button on the Display Module to calibrate the channel.
10. This can be repeated for each channel in the control rack.
11. Once the system has been fully checked return the Display Module and input cards to normal operation using the pushbuttons mounted on the front panel.

3.2.10 Set-up and Operation: 2 wire 4-20 mA flameproof devices

3.2.10.1 General

The 2 wire 4-20 mA flameproof detectors may be fitted with various electrochemical sensors to monitor toxic gases and oxygen.

Each detector is 4-20 mA loop powered and includes a local amplifier. The 420 mA output is proportional to the gas concentration at the detector. The 2 wire 4-20 mA flameproof devices are 4-20 mA sink devices.

The 4-20 mA gas detectors must be calibrated independently of the Gasmonitor+ control system. For details please refer to the relevant Installation, Operating and Maintenance Instructions provided with each detector.

3.2.10.2 Cabling Requirement

Cabling to the detector must be in accordance with the recognised standards of the appropriate authority in the country concerned and meet the electrical requirements of the detector.

Crowcon recommend the use of steel wire armoured (SWA) cable and suitable explosion proof glands must be used.

Alternative cabling techniques, such as steel conduit, may be acceptable provided appropriate standards are met.

Gasmonitor+ supplies a guaranteed minimum supply voltage of 22 Vdc. Please refer to the relevant Installation, Operating and Maintenance Instructions provided with each detector to calculate the maximum cable distances allowed for different cable types.

3.2.10.3 Earthing

The junction box and cable armour must be earthed at either the detector or control panel to limit the effects of radio frequency interference. It is good

practice to provide the earth connection at the safe area **only**, so as to avoid earth loops.

3.2.10.4 Universal Gas Input Card Jumper Settings

For details of all jumper settings refer to Hardware, Universal Gas Input Card, Jumper Settings, section 2.3.5.

As standard the jumper settings required are:

Link	Position
LK 1	A, C, A-B, C-D
LK 2	E, I, K, E-F, I-J, K L
LK 3	None
LK 4	4-20
LK 5	24V
LK 6 and 7	24V C/C

Alternative LK 2 and LK 3 settings may be required. Refer to Hardware, Universal Gas Input Card Jumper Settings , section 2.3.5.

3.2.10.5 Setting to Work

The detector must be calibrated before calibration of the associated input card. For calibration details of 4-20 mA gas detectors please refer to the Installation, Operating and Maintenance Instructions provided with each detector.

3.2.10.6 Calibration

Calibration of the input card may be performed via the four pushbuttons or the SetGmon software provided. Where single channels require calibration Crowcon recommend the following procedure. Where many channels are to be calibrated Crowcon recommend the use of SetGmon (see Appendix B).

Calibration gas and accessories are available from Crowcon.

When calibrating an input card and detector for the first time Crowcon recommend that two persons be used, one at the detector and the other at the control panel. When gas is applied to the detector in the field the person at the control panel can check that the detector is connected to the correct input card by observing the gas reading or bar graph on the front panel.

Once the link between the detector and input card has been proved one person can carry out future calibrations and routine functional testing (see Routine Functional Testing, section 3.2.9.8).

To calibrate the input card for use with a 4-20mA type detector:

1. Inhibit the input card of the channel to be calibrated by pressing the INHIBIT button on the input card and the RESET button on the Display Module simultaneously.
2. Ensure that the associated detector is reading zero gas level, i.e., output is 4 mA. For an oxygen sensor, the sensor must be disconnected from the current amplifier at the detector head.
3. Using the four pushbuttons on the Display Module select ZERO?
4. Using the four pushbuttons on the Display Module select the channel to be zeroed.
5. Zero the channel by following the commands on the Display Module. On completion the message 'Zero successful' is displayed.
6. Using the four pushbuttons on the Display Module select CALIBRATE?
7. Using the four pushbuttons on the Display Module select the channel to be calibrated.
8. Apply calibration gas to the detector (normally half scale).
9. Allow the gas level reading on the Display Module to stabilise and then adjust the displayed value by pressing the UP and DOWN pushbuttons on the Display Module until the displayed value corresponds to the calibration gas applied.
10. Press the YES button on the Display Module to calibrate the channel.
11. The detector and input card are now configured and calibrated correctly.
12. Return the Display Module and input card to normal operation using the pushbuttons mounted on the front panel.

3.2.10.7 Routine Functional Testing

Crowcon recommend that detectors be routinely checked to ensure correct calibration and operation. This should be carried out at least every 6 months, however, site procedures may stipulate more frequent checks.

One person may check a detector with a local amplifier at the detector and no adjustment at the control panel should be required.

Depending on the detector functionality it may be necessary to inhibit the associated input card before attempting routine functional testing of the detector.

For detailed instructions on the routine functional testing of the detectors please refer to the relevant Installation, Operating and Maintenance Instructions provided with each detector.

The calibration of the input card should be checked annually as a minimum. To check the input cards calibration:

1. Inhibit all input cards in any single control rack by pressing the INHIBIT button on each input card and the RESET button on the Display Module simultaneously.
2. Ensure that the detectors are reading zero gas, i.e., detector output set to 4 mA.
3. Using the four pushbuttons on the Display Module re-zero each input card as necessary.
4. Using the four pushbuttons on the Display Module select HOLDALL CAL?
5. Pressing the YES button instructs the Display Module to log the peak gas reading from each input card. The message 'Collecting Peaks' is displayed during this operation.
6. Apply calibration gas to each detector in turn and return to the control panel.
7. Pressing the DONE button on the Display Module displays the message 'ADJ Ch1 > XXX?' where XXX is the name given to that channel.
8. Upon pressing the YES button on the Display Module the user may adjust the reading by pressing them UP and DOWN buttons until the reading displayed matches the calibration gas used.

9. Press the YES button on the Display Module to calibrate the channel.
10. This can be repeated for each channel in the control rack.
11. Once the system has been fully checked return the Display Module and input cards to normal operation using the pushbuttons mounted on the front panel.

3.3 Fire Detector Installation and Operation

3.3.1 Approved Detectors

Gasmonitor+ has been designed primarily as a gas detection system. However, Gasmonitor+ may be used to control a range of fire detection equipment.

Gasmonitor+ has been tested for use with the Series 60 range of fire detectors available from Apollo. Other manufacturer detectors may be suitable, contact Crowcon for further details.

A switch operating in series or parallel with sense resistors may represent a fire detector. This is shown in Figure 32.

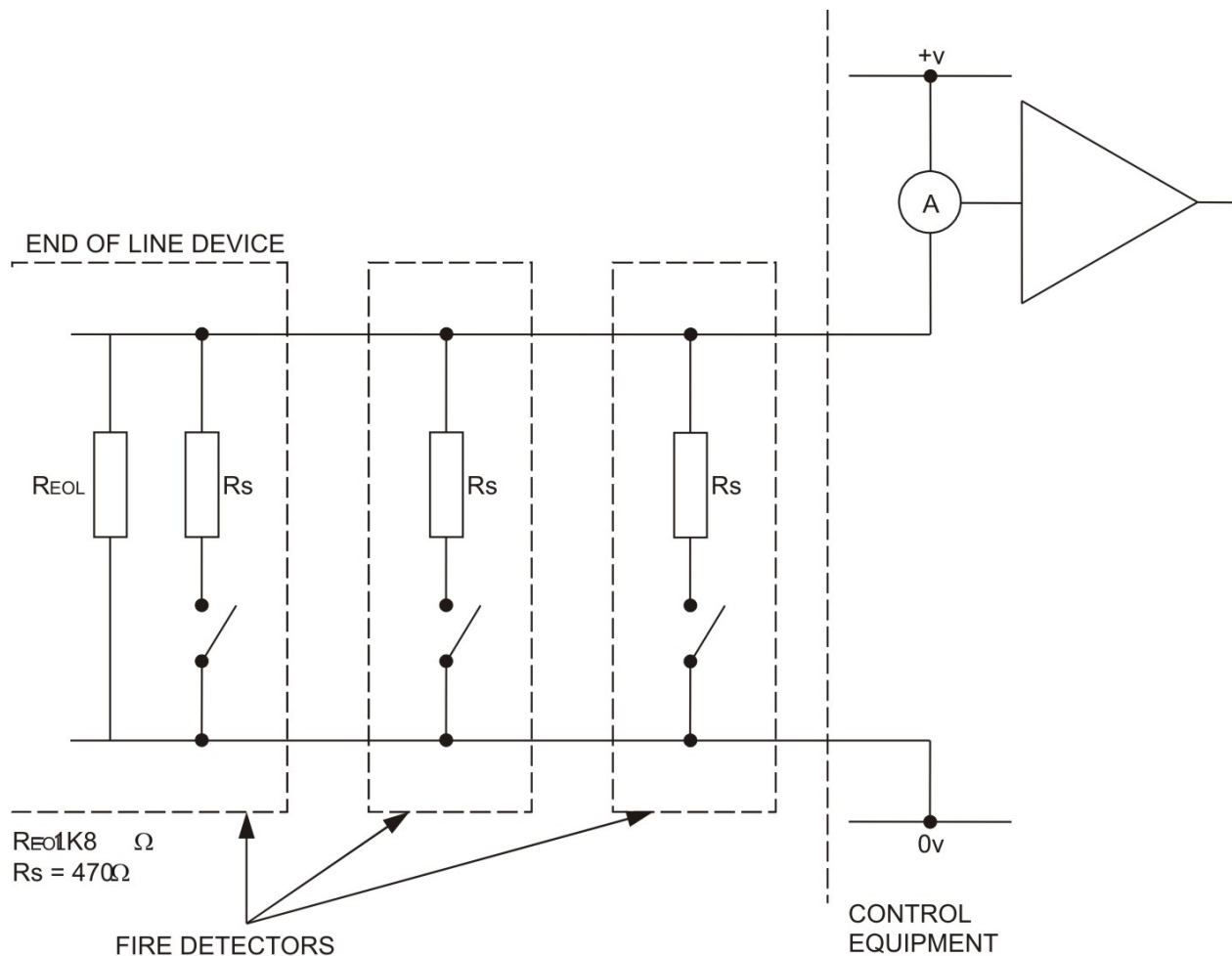

Figure 32: Fire Detection Circuit Schematic Representation

With no detectors in alarm (all switches open) a small current flows in the circuit through the end of line resistor (R_{EOL}). If a short circuit or open circuit cable fault occurs, the current in the loop increases or decreases. The input card detects this and a fault alarm is raised.

Should a fire be detected (switch closes) then the current flowing in the loop changes and the input card detects this and a fire alarm is raised.

Gasmonitor+ has been designed to operate fire detectors given the following characteristics of the Twin Zone Fire Input Card.

Alarm Window	Loop Current
Open circuit fault	< 2.5 mA
Normal operation (no fire detected)	8 mA to 15 mA
Fire detected	20 mA to 53 mA
Short circuit fault	> 58 mA

Up to 20 Series 60 fire detection devices may be used on the same loop at any time. Devices on the loop may be mixed provided electrical characteristics are compatible and fire regulations allow.

Where manual alarm call points or other switched devices are used series and end of line resistors should be fitted to ensure correct alarm detection by the Twin Zone Fire Input Card (series resistor = 470 Ohms, end of line resistor = 1K8 Ohms)

3.3.2 Detector Location

It is beyond the scope of this manual to describe the rules and regulations governing the installation of fire detection equipment.

Assistance and guidance should be sought from the governing body in the country concerned before fire detection equipment is installed.

Further advice is available from Crowcon if required.

3.3.3 Set-up Procedure: Generic to all Fire Detectors and Manual Alarm Call Points

3.3.3.1 Cabling Requirement

Cabling to fire detectors must be in accordance with the recognised standards of the appropriate authority in the country concerned and meet the electrical requirements of the detector.

Crowcon recommend the use of twisted pair, screened with overall protective sheath which is fireproof, e.g., Pirelli FP200 or similar. Suitable weatherproof glands must be used.

Alternative cabling techniques, such as steel conduit, may be acceptable provided appropriate standards are met.

The maximum acceptable loop resistance is 100 Ohms. The following table summarises the maximum cable length allowed for up to 1.0 mm² cross sectional area (c.s.a.) cable.

c.s.a (mm ²) ¹	Typical Resistance per Km of Cable (Ohms)	Typical Loop Resistance per Km of Cable (Ohms)	Maximum Cable Length (m) ²
0.5 (20)	39.0	78.0	1000 (3280)
1.0 (17)	18.1	36.2	2500 (8200)

Notes:

¹ *Approximate c.s.a. in awg given in brackets.*

² *Approximate distance in feet given in brackets.*

3.3.3.2 Earthing

It is essential to observe the correct earthing arrangement when using intrinsically safe fire detectors.

When mounted in a safe area (no line isolators), or is used with a galvanic isolator, the junction box and cable screen must be earthed at either the detector or control panel to limit the effects of radio frequency interference. It is good practice to provide the earth connection at the safe area **only**, so as to avoid earth loops.

When used with a Zener barrier a certified IS earth is required at the Zener barrier. The cable screen must be earthed at the IS earth to meet intrinsic safety requirements and to limit the effects of radio frequency interference.

When Zener barriers are used the link GND2 must be removed from the motherboard of the 19" control rack.

3.3.3.3 Twin Zone Fire Input Card Jumper Settings

When using Zener barriers ensure that the link LK1 on the Twin Zone Fire Input Card is fitted.

3.3.3.4 Electrical Connections

Figure 33 details the typical electrical connections to be made to the Input/Output Module.

For further termination detail refer to Figure 17.

3.3.3.5 Routine Functional Testing

Crowcon recommend that fire detectors be tested every 3 to 6 months. Site procedures may stipulate more frequent testing.

For details on how to test different fire detectors please refer to the relevant Installation, Operation and Maintenance Instructions provided with the detector.

Prior to carrying out functional tests it may be necessary to isolate automatic shutdown signals and/or inhibit the associated input card to prevent accidental trips.

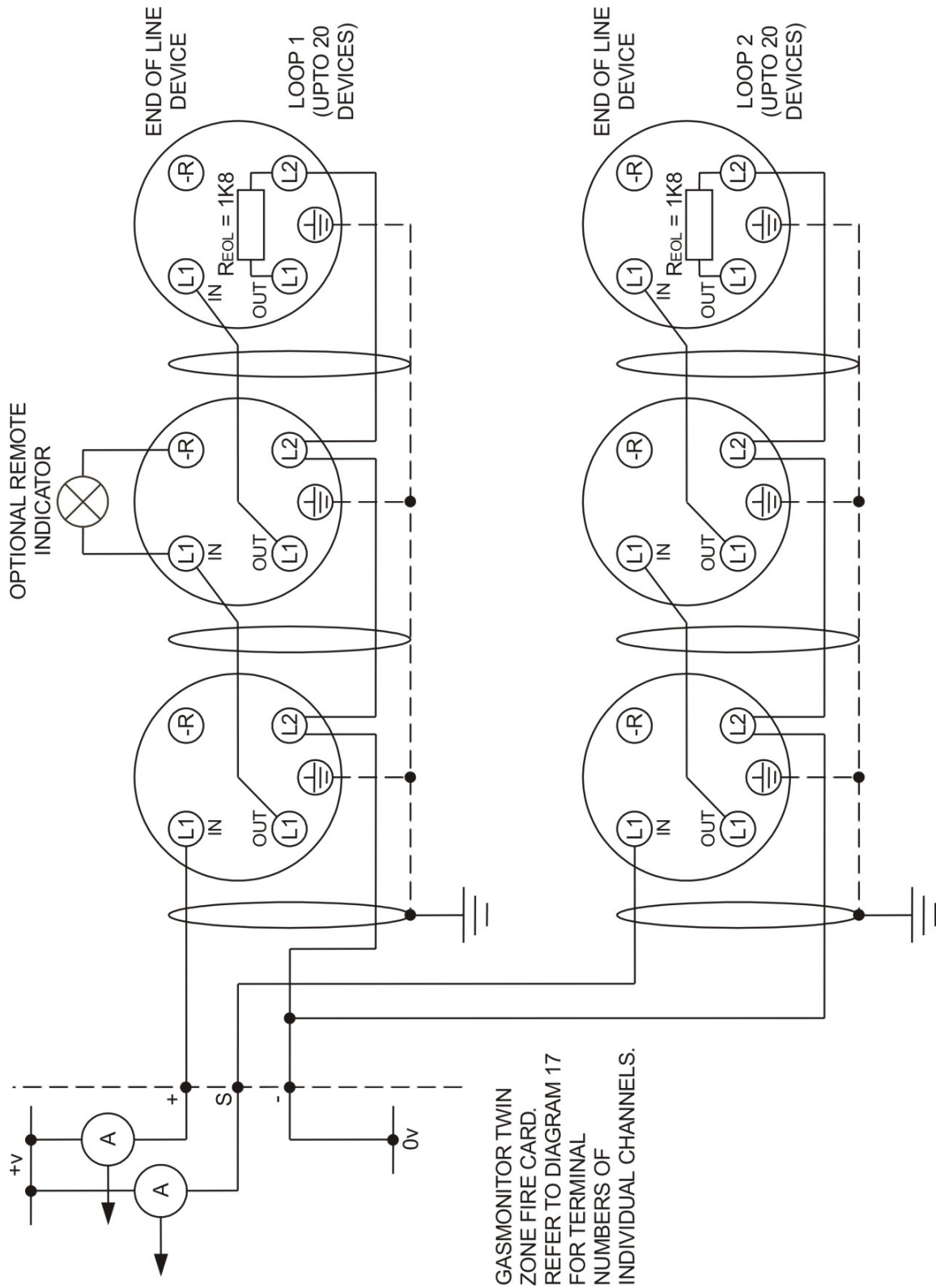

Figure 33 (a): Gasmonitor+ to Series 65 Fire Detectors Wiring Detail (Safe Area Only)

FIELD DEVICES

FFIELD DEVICES

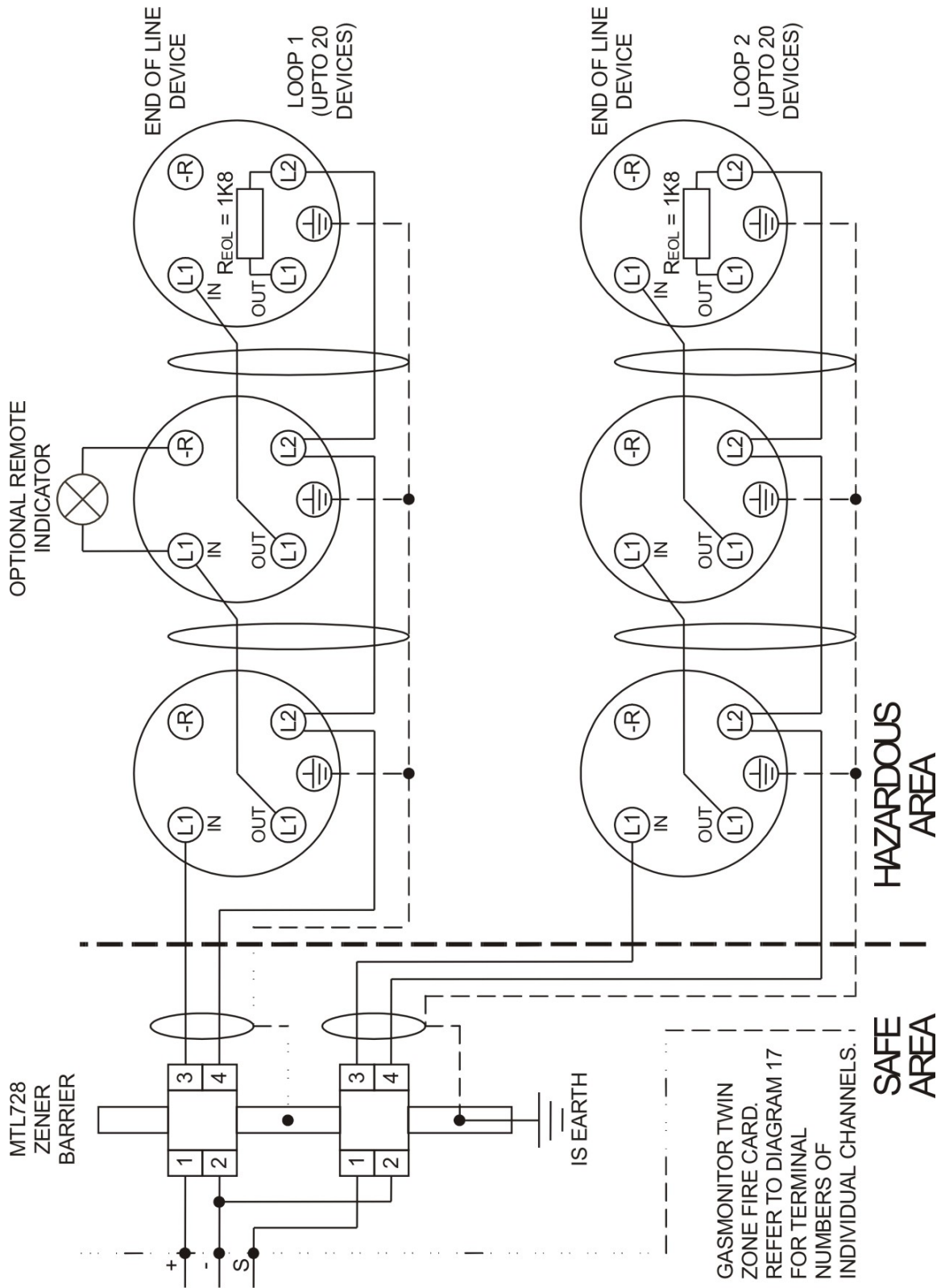

Figure 33 (b): Gasmonitor+ to Series 65 Fire Detectors Wiring Detail (Hazardous Area)

3.3.3.6 Dummy Loads

For test purposes, and to prevent fault alarms on channels that have no heads connected, detectors can be simulated by dummy resistive loads as shown below. Figure 34 (a) to (d) shows terminal numbers on the input/output module for channel 1, but of course dummy loads can be fitted in the same manner to any channel.

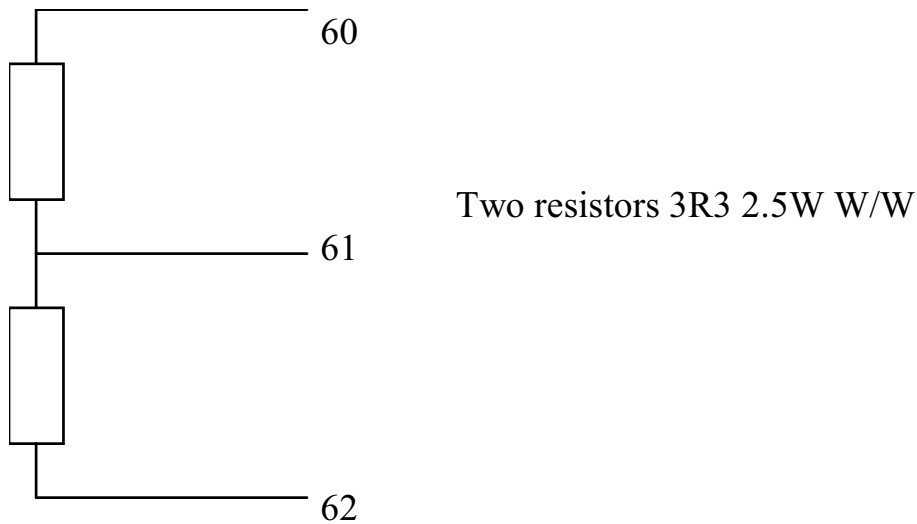

Figure 34 (a): Pellistor 3-wire mV Bridge

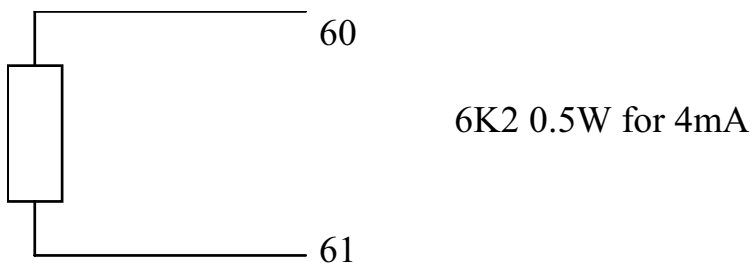
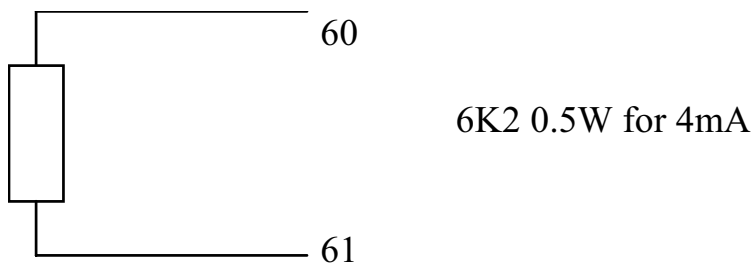

Figure 34 (b): 4-20mA Current Sink – Toxics

FIELD DEVICES



Notes:

1 Current flows are approximate.

2 4-20mA input settings must be for external sink to utilise dummy loads.

Figure 34 (c): 4-20mA Current Sink – Oxygen

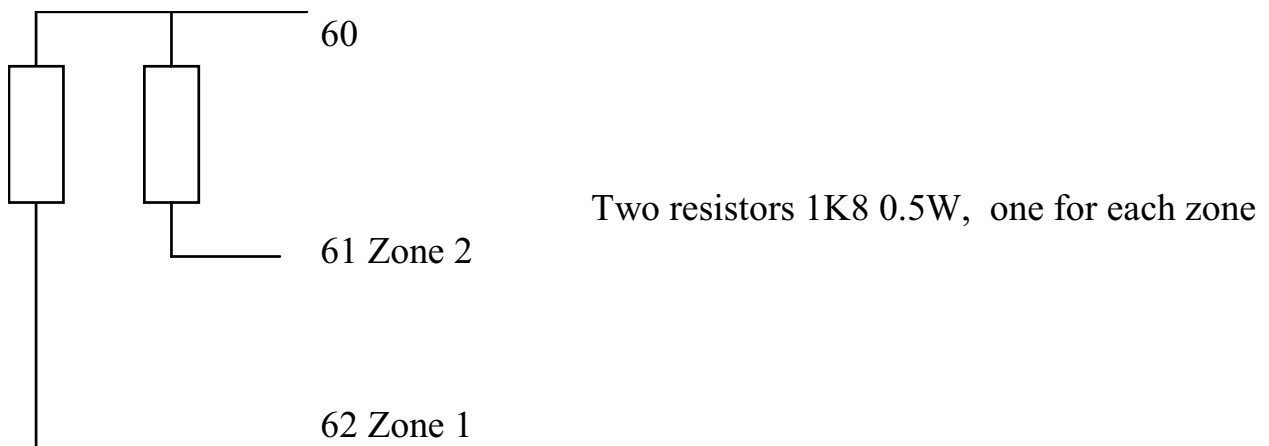

Figure 34 (d): Fire Channels

3.4 Audible/Visual Alarm Installation

3.4.1 Dedicated Drives for Audible/Visual Alarms

Gasmonitor+ is able to drive audible and visual alarms via common alarm relay outputs. The type and function of these alarm devices is beyond the scope of this manual.

Gasmonitor+ includes four dedicated audible/visual alarm drives as detailed in Hardware, Display Module, Dedicated Audible and Visual Alarm Drive Operation, section 2.2.2.2. These are shown in Figure 35.

Any 24 V dc field device may be driven by the dedicated outputs provided the maximum current drawn on each output is less than 200 mA.

3.4.1.1 Cabling Requirement

The type of cable used and the size of conductors should be chosen to suit the field device installed. Please refer to the Installation, Operation and Maintenance Instructions of the audible/visual alarm to be used for details.

Cabling to the device must be in accordance with the recognised standards of the appropriate authority in the country concerned and meet the electrical requirements of the device.

Gasmonitor+ supplies a guaranteed minimum supply voltage of 22 Vdc.

FFIELD DEVICES

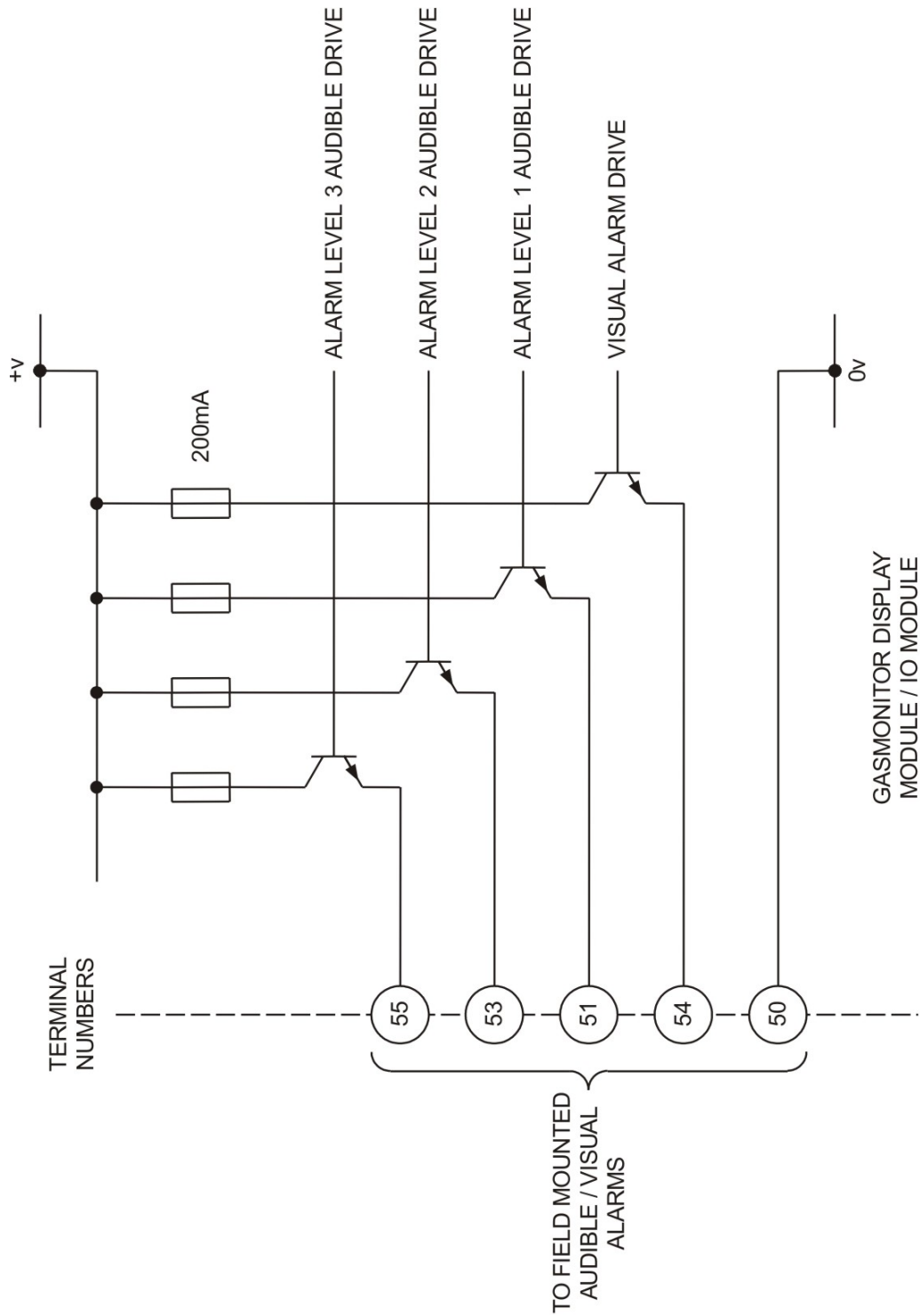

Figure 35: Dedicated Audible/Visual Alarm Drives

3.4.1.2 Earthing

For flameproof equipment, devices driven through galvanic isolators or equipment mounted in safe areas the junction box of the field device and cable armour/screen must be earthed at either the detector or control panel to limit the effects of radio frequency interference. It is good practice to provide the earth connection at the safe area **only**, so as to avoid earth loops.

Where the field device is driven through a Zener barrier then the screen must be earthed at the IS earth at the barrier. Remove link GND2 on the 19" rack motherboard when using Zener barriers.

3.4.1.3 Electrical Connections

Figure 36 details typical electrical connections to different audible and visual alarm devices available from Crowcon. Other devices may be used as appropriate.

For further assistance please contact Crowcon.

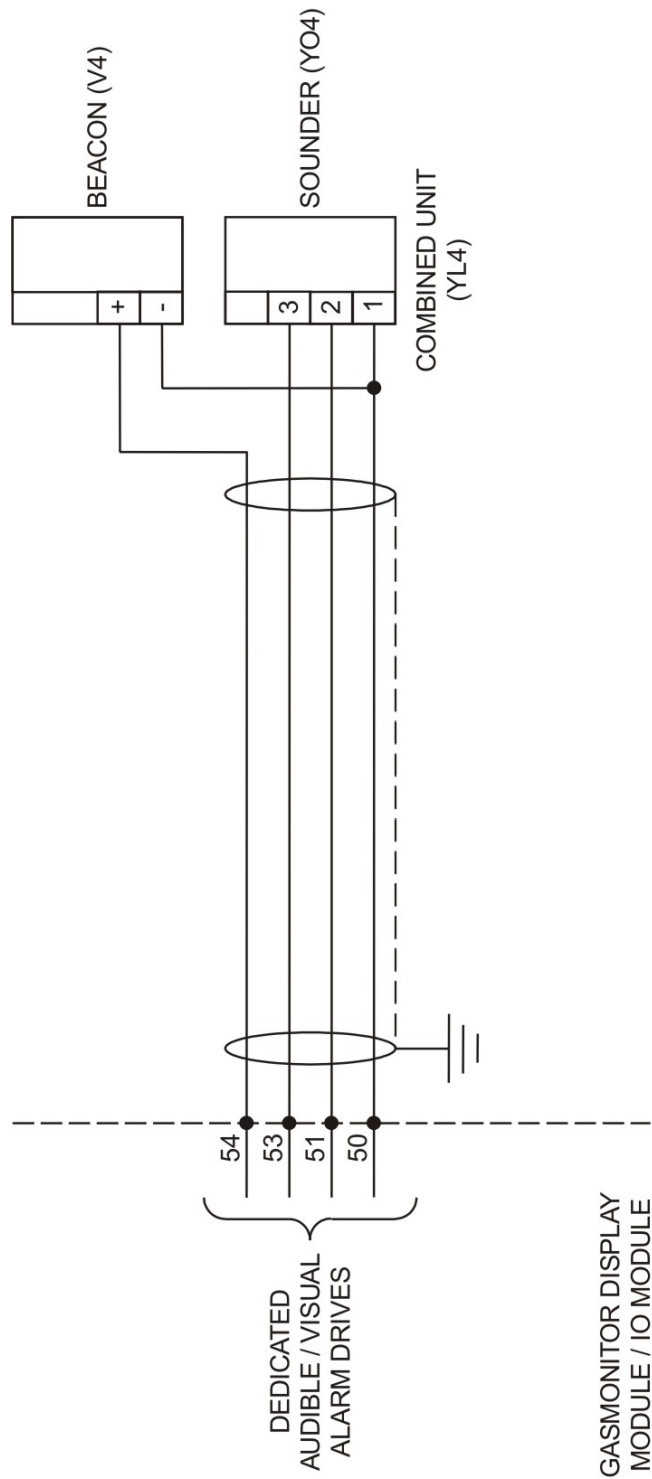

Figure 36 (a): Audible/Visual Alarms Typical Wiring Detail (Safe Area Only)

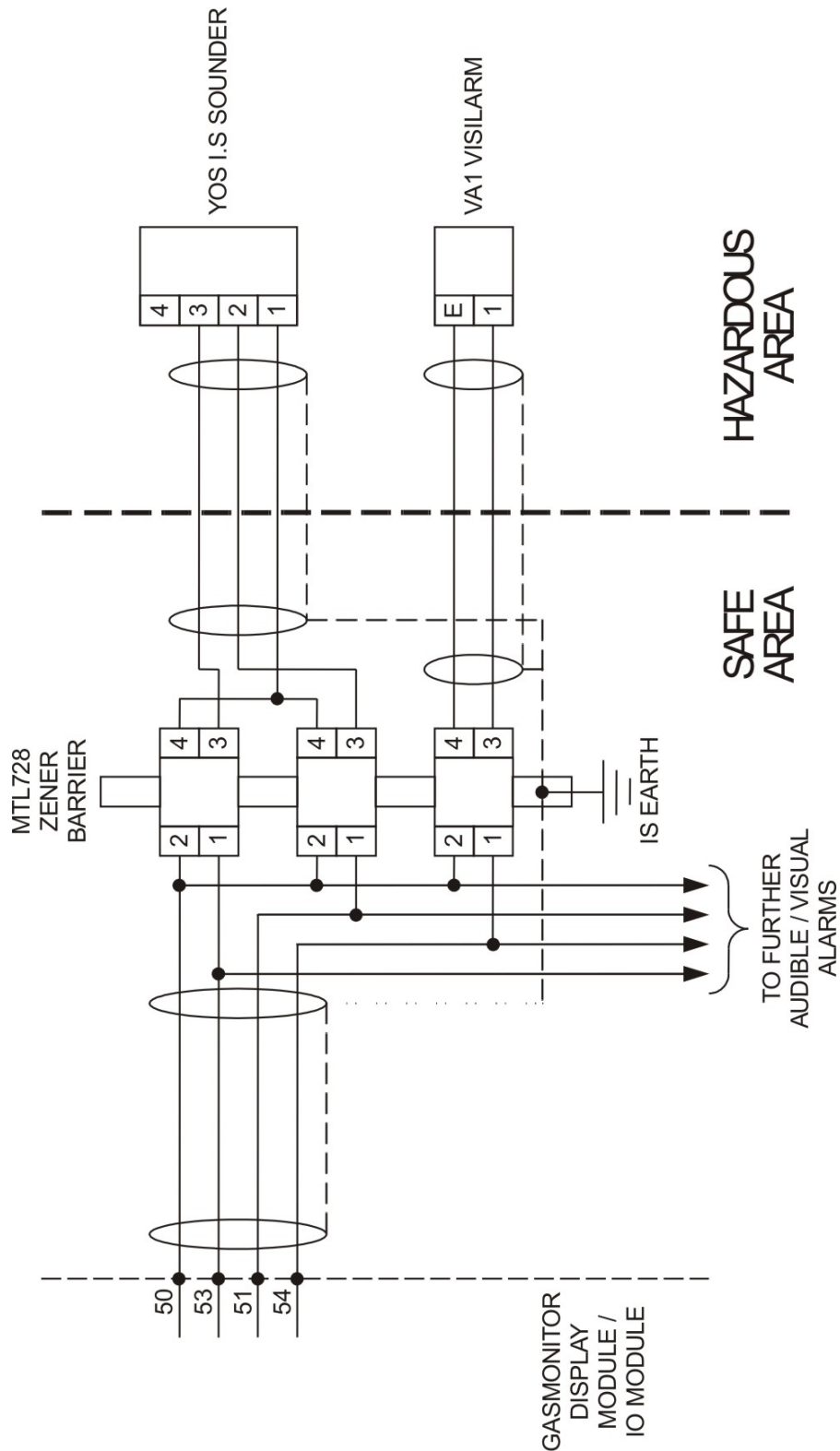
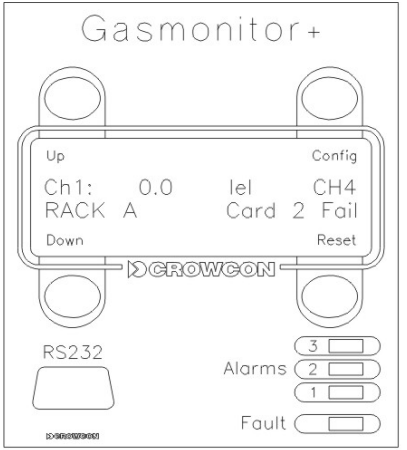



Figure 36 (b): Audible/Visual Alarms Typical Wiring Detail (Hazardous Area)



FIELD DEVICES

APPENDIX A DISPLAY MODULE MENU OPERATION

This Appendix should be read in conjunction with the relevant Set-up and Operation procedures given in Field Devices, section 3.

Command	Description	Typical Display
	<p>Normal operation display as shown.</p> <p>Press 'Up' or 'Down' buttons to cycle through channels fitted with gas detectors.</p> <p>Press 'Config' to display the '>SELFTEST?' menu.</p>	
>SELF TEST?	<p>Press 'YES' to carry out self-test. Successful completion proves the integrity of the processors, their communication and the functionality of the LEDs.</p> <p>Press 'NO' to display the '>BACKLIGHT?' menu.</p> <p>Press 'QUIT' to return to normal operation.</p> <p>Note <i>If no buttons are pressed then the display will return to normal operation after 5 seconds.</i></p>	

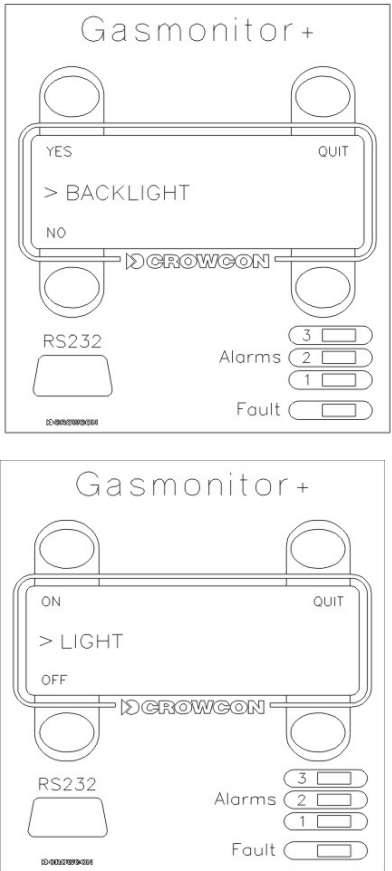
APPENDICES

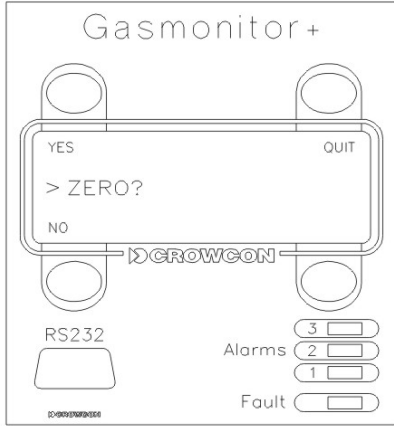
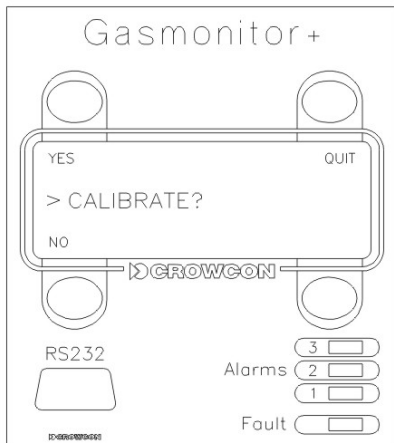
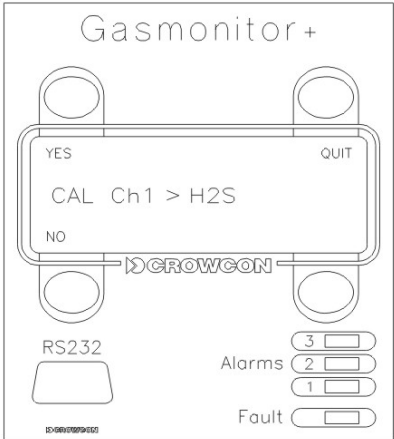

Command	Description	Typical Display
<p>>BACKLIGHT?</p>	<p>Press ‘YES’ to display the sub-menu and then press ‘ON’ or ‘OFF’ to operate the backlight on the display. Press ‘QUIT’ to return to the ‘>BACKLIGHT?’ menu.</p> <p>Press ‘NO’ to display the ‘>MORE?’ menu.</p> <p>Note: <i>If no buttons are pressed then the display will return to normal operation after 5 seconds.</i></p>	
<p>>MORE?</p>	<p>This option enables access to further menus which allow the user to make simple configuration changes.</p> <p>Press ‘YES’ to proceed and the display will go blank. The correct password (press buttons in sequence (1, 2, 3, 4 as shown on diagram)) must be entered within 5 seconds, if not, the display will return to normal operation.</p> <p>If the password is entered correctly the ‘>ZERO?’ option is displayed.</p> <p>Note: <i>The three red alarm LEDs will flash rapidly to highlight that</i></p>	

Command	Description	Typical Display
	<p><i>the system Is permanently in configuration mode until reset. In this mode no common alarms or Voted Relay outputs will operate.</i></p>	
<p>>ZERO?</p>	<p>To zero a channel:</p> <ol style="list-style-type: none"> 1. Press ‘YES’ to display ‘>ZERO Ch1 >XXX?’. 2. Press ‘NO’ to step to the channel to be zeroed and then press ‘YES’. 3. The message ‘Zero successful’ will be displayed. 4. Press ‘CONT’ to zero another channel or ‘END’ to return to normal operation. <p>Notes:</p> <ol style="list-style-type: none"> 1 <i>Ensure that gas is not present at the detector before zeroing a channel.</i> 2 <i>In the case of detectors with local amplifiers ensure the detector Is calibrated before zeroing the input card.</i> 3 <i>Pellistor type flammable gas detectors must be set up before zero or calibration (see ‘>SET FLAMHEAD?’ menu).</i> 	<p>The typical display section contains three screenshots of the Gasmonitor+ device's LCD screen. Each screenshot shows the device's interface with a 'GASMONITOR+' header, an 'RS232' label, and three indicator lights for 'Alarms' (1, 2, 3) and 'Fault'. - The first screenshot shows the prompt '>ZERO?' with 'YES' on the left and 'QUIT' on the right. - The second screenshot shows the prompt 'ZERO Ch1 > xx' with 'YES' on the left and 'QUIT' on the right. - The third screenshot shows the confirmation 'ZERO SUCCESSFUL' with 'CONT' on the right and 'END' on the left.</p>

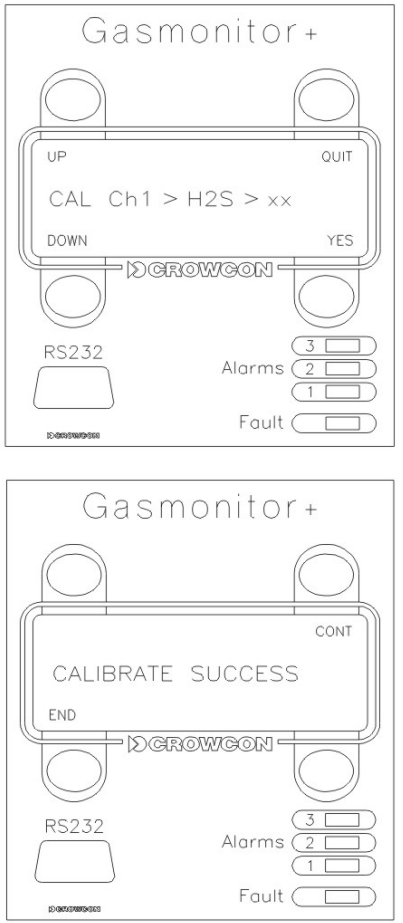
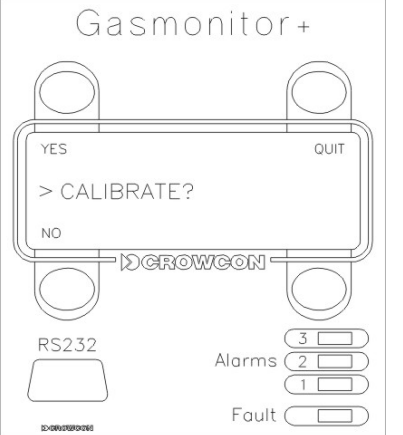
Command	Description	Typical Display
>ZERO?	Press 'NO' to display the '>CALIBRATE?' menu.	 <p>The display shows 'Gasmonitor+' at the top. Below it is a menu with 'YES' on the left and 'QUIT' on the right. The central text reads '> ZERO?'. At the bottom left of the menu is 'NO'. Below the menu is the 'CROWCON' logo. At the bottom left of the device is 'RS232'. On the right side, there are four indicator lights labeled 'Alarms' (3, 2, 1) and 'Fault'.</p>
>CALIBRATE?	<p>To calibrate a single channel:</p> <ol style="list-style-type: none"> 1 Press 'YES' to display '>CAL Ch1>XXX?'. 2 Press 'NO' to step to the channel to be calibrated and then press 'YES'. 3 The message 'CAL ChX>XXX?>n.nn' is displayed. 4 Apply calibration gas to the detector and allow reading to stabilise. 5 Press 'Up'/'Down' to adjust reading 'n.nn' to read correctly. 6 Press 'YES' to set the calibration. 7 The message 'Calibrate success' will be displayed. If not the detector may need replacing. Contact Crowcon for assistance. 8 Press 'CONT' to calibrate another channel or 'END' to return to normal operation. 	 <p>The display shows 'Gasmonitor+' at the top. Below it is a menu with 'YES' on the left and 'QUIT' on the right. The central text reads '> CALIBRATE?'. At the bottom left of the menu is 'NO'. Below the menu is the 'CROWCON' logo. At the bottom left of the device is 'RS232'. On the right side, there are four indicator lights labeled 'Alarms' (3, 2, 1) and 'Fault'.</p>  <p>The display shows 'Gasmonitor+' at the top. Below it is a menu with 'YES' on the left and 'QUIT' on the right. The central text reads 'CAL Ch1 > H2S'. At the bottom left of the menu is 'NO'. Below the menu is the 'CROWCON' logo. At the bottom left of the device is 'RS232'. On the right side, there are four indicator lights labeled 'Alarms' (3, 2, 1) and 'Fault'.</p>

Command	Description	Typical Display
	<p>Notes:</p> <p><i>1 Detectors with local amplifiers should be calibrated before calibrating the input card.</i></p> <p><i>2 Pellistor type flammable gas detectors must be set up before zero or calibration (see '>SET FLAMHEAD?' menu).</i></p>	
<p>>CALIBRATE?</p>	<p>Press 'NO' to display the '>HOLDALLCAL?' menu.</p>	

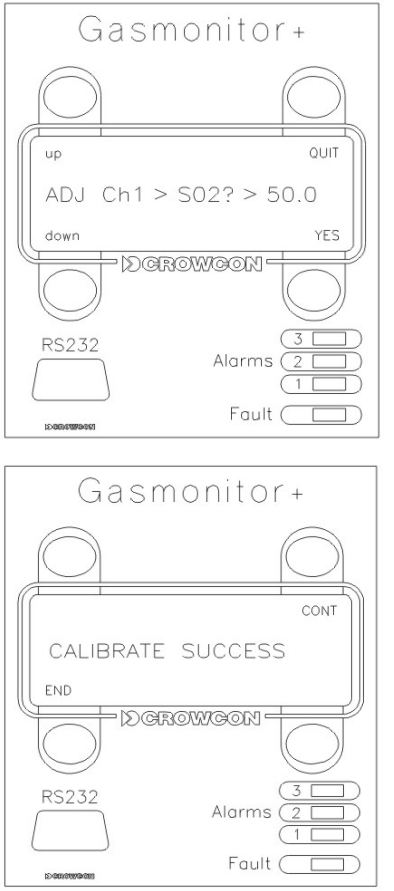
Command	Description	Typical Display
<p>>HOLD ALL CAL?</p>	<p>To calibrate multiple channels:</p> <ol style="list-style-type: none"> 1. Press ‘YES’ to display the message ‘Collecting Peaks’. 2. Apply calibration gas to each of the detectors to be calibrated. Allow time for detector to respond and stabilize (typically 30 seconds). 3. Press ‘Done’ to display the ‘ADJChN> XXX?’ menu. 4. Press ‘NO’ to step to the channel to be calibrated and then press ‘YES’ to display ‘ADJ ChN> XXX>n.nn’ 5. Press ‘Up’/’Down’ to adjust reading ‘n.nn’ to read correctly for the gas applied to that channel. 6. Press ‘YES’ to set the calibration. 7. The message ‘Calibrate success’ will be displayed. If not the detector may need replacing. Contact Crowcon for assistance. 8. Press ‘CONT’ to calibrate another channel or ‘END’ to return to normal operation. <p>Notes:</p> <ol style="list-style-type: none"> 1. <i>Detectors with local amplifiers should be calibrated before calibrating the input card.</i> 2. <i>Pellistor type flammable gas</i> 	

Command	Description	Typical Display
	<p><i>detectors must be set up before zero or calibration (see '>SET FLAMMHEAD?' menu).</i></p> <p>3. Prior to commencing this routine, inhibit all active channels on the rack, even those not being calibrated, to eliminate the possibility of false alarms.</p>	
>HOLD ALL CAL?	Press 'NO' to display the '>SET FLAMMHEAD?' menu.	

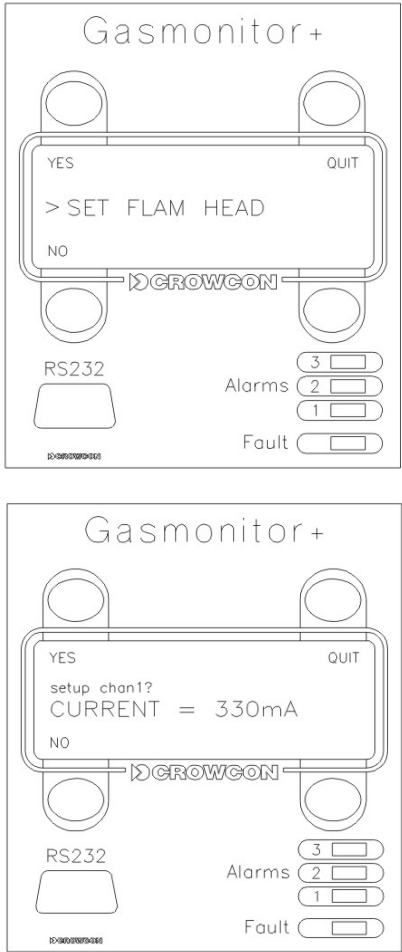
Command	Description	Typical Display
<p>>SET FLAMMABLE HEAD?</p>	<p>To set-up a pellistor type flammable gas detector:</p> <ol style="list-style-type: none"> 1 Press 'YES' to display the 'setup chan N?' menu. 2 Press 'NO' to step to the channel to beset-up and then press 'YES' to display 'CURRENT=XXXmA'. 3 Measure the head voltage at the detector using a DVM. 4 Open the drop down front panel of the control rack. 5 Adjust the HEAD CURRENT potentiometer on the associated input card until the head voltage at the detector reads correctly (see detector instructions). 6 Adjust the BALANCE potentiometer on the associated input card until the LED on the bargraph is positioned centrally. 7 The channel is now ready to be calibrated. 8 Press 'QUIT' to return to the '>SET FLAM HEAD?' menu. 9 Press 'QUIT' to return to normal operation. <p>Note: <i>See Field Devices, section 3.2.7, for set-up procedure.</i></p>	 <p>The top screenshot shows the control panel with the display reading 'Gasmonitor+' at the top, 'setup chan1?' below it, and 'CURRENT = 330mA' in the center. The bottom screenshot shows the control panel with the display reading 'Gasmonitor+' at the top, 'setup chan1?' below it, and 'CURRENT = 330mA' in the center. Both screenshots show the 'YES' and 'QUIT' buttons at the top of the display area, and the 'NO' button at the bottom left. The control panel also features an RS232 port, a bargraph, and three alarm indicators labeled 'Alarms' and 'Fault'.</p>
<p>>SET FLAMMABLE</p>	<p>Press 'NO' to display the '>FORCEINPUTS?' menu.</p>	

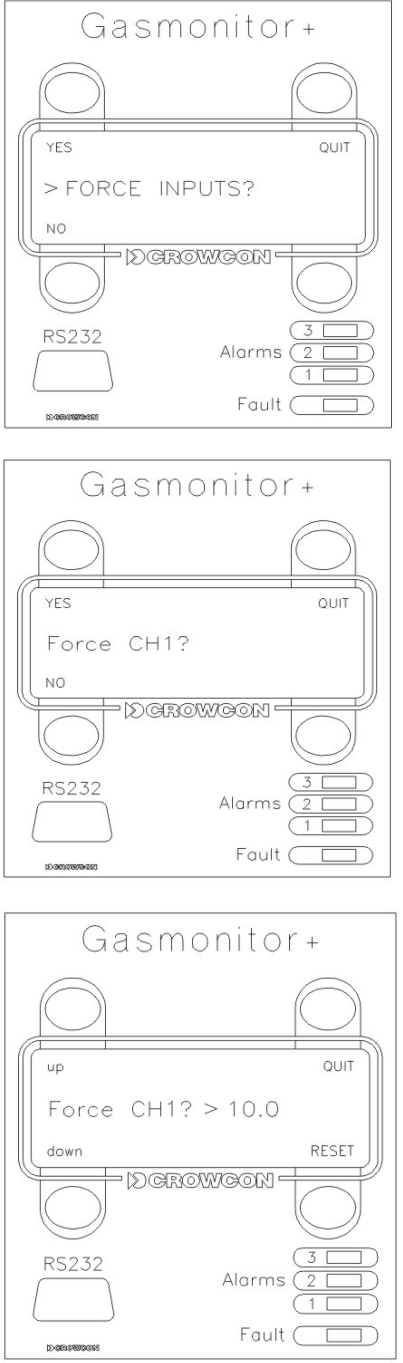
Command	Description	Typical Display
HEAD?		
>FORCE INPUTS?	<p>To force a channel input:</p> <ol style="list-style-type: none"> 1 Inhibit the channel to prevent false alarms if required. 2 Press 'YES' to display the '>Force ChN?' menu. 3 Press 'NO' to step to the channel to be forced and then press 'YES' to display 'Force ChN?>n.nn'. 4 Press 'Up'/'Down' to force the input card up or downscale. 5 Pressing 'QUIT' to return to the '>FORCE INPUTS?' menu. 	 <p>The typical display section contains three screenshots of the Gasmonitor+ interface. The first screenshot shows the main menu with 'Gasmonitor+' at the top, 'YES' and 'QUIT' at the top corners, and '> FORCE INPUTS?' in the center. Below the screen are four pushbuttons labeled '3', '2', '1', and 'Fault'. The second screenshot shows the 'Force CH1?' menu with 'YES' and 'QUIT' at the top corners and 'NO' at the bottom left. The third screenshot shows the 'Force CH1? > 10.0' menu with 'up' and 'QUIT' at the top corners, 'down' and 'RESET' at the bottom corners, and the 'CROWCON' logo in the center.</p>
>FORCE INPUTS?	Press 'NO' to display the '>ALARM LEVEL?' menu.	

The following features are also available for adjustment via the 4 pushbuttons, however, Crowcon recommend the use of SetGmon. See Appendix B for details.

- >ALARM LEVEL ?
- >ALARM LATCH ?
- >ALARM SENSE ?
- >RELAY DRIVE ?
- >CHAN FLAGS ?

APPENDIX B WINDOWS BASED SOFTWARE FOR THE PC

Contents

General	106
Software Installation	106
Electrical Connections	106
SetGmon Software	107
Overview	107
Running SetGmon for the First Time	107
Establishing Communications	108
Configuration Files	110
General	110
Editing Configuration Files	114
Making System Adjustments via SetGmon	120
Special Functions	122
LogManager Software	123
Overview	123
Running LogManager	123
Viewing a Logged File	123
‘Convert’ing Files to .CSV Format	124
‘Save As’ .CSV Files to Disc	125
‘Print’ing Logged Data	126

General

Each Gasmonitor+ system is supplied with:

3 ½" floppy disc containing SetGmon and LogManager software. 9 way D type PC to Gasmonitor+ connecting lead.

The minimum PC requirements are:

IBM compatible PC, 386 or better, minimum 16Mb RAM running Windows 3.11 or later.

Software Installation

To install the Windows software under Windows 95 or later:

- 1 Insert the 3 ½" floppy disc provided into drive 'A'
- 2 Select 'Run...' from the 'Start' menu
- 3 Type 'A:Setup' in the pop up box and press 'OK'

The software will be loaded automatically and the following programs will appear in the '**Programs**' menu.

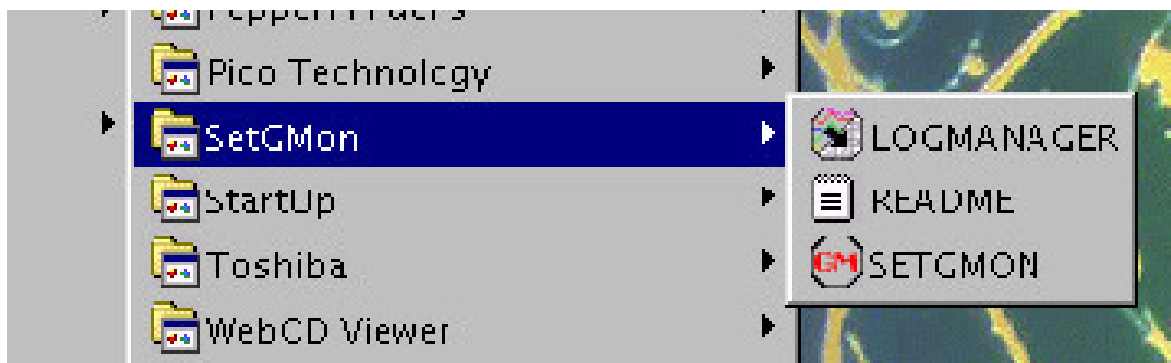

Electrical Connections

Gasmonitor+ is connected to the PC using the 9 way D type connecting lead provided (Crowcon part no. C01327).

The connecting lead is polarised. Ensure the end labelled 'INSTRUMENT' is connected to the RS232 port on the front of the Gasmonitor+ Display Module.

Alternatively, the lead may be permanently connected to the RS232 port located on the motherboard.

The other end of the connecting lead is plugged into the 9 way D port (COM1) on the PC.

If COM1 is being used e.g. by the mouse, COM2 may be used but the WIN.INI file must be amended to include the following instructions:

```
[setgmon]
port=2 (A carriage return is required after the number 2)
```

SetGmon Software

Overview

SetGmon has four main functions:

- Adjustment of the Gasmonitor+ system from the PC.
- Creation, modification and storage of system configuration files.
- The transfer of configuration files to and from Gasmonitor+.
- Collection of logged data for use by **LogManager**.

All functions are carried out using the on screen pop up menus which are discussed in the following sections.

Running SetGmon for the First Time

Select 'SetGmon' from the 'Start' menu. The following screen will appear:

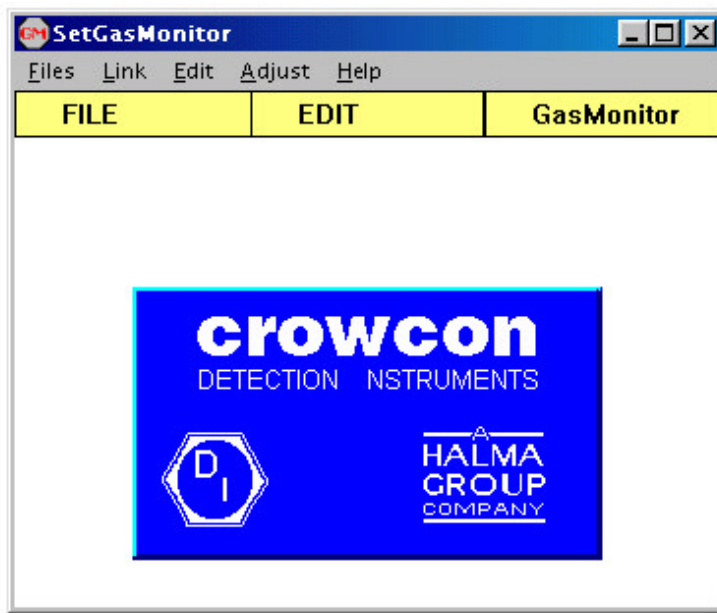

If upon running SetGmon the following error message occurs, check the cable is connected securely, the correct COM port is being used or that the COM port is not already in use by another program.

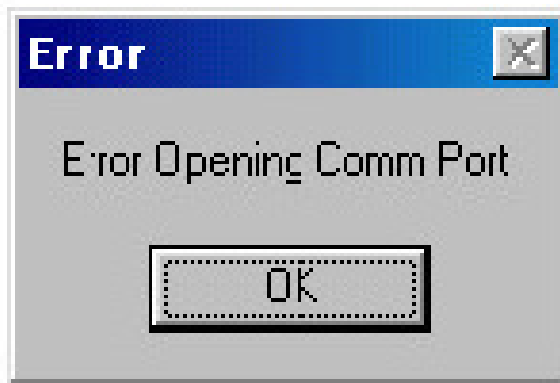

Establishing Communications

As standard SetGmon talks to a single Gasmonitor+ via the 9 way connecting cable provided.

It is possible for several multi-dropped Gasmonitor+ control racks to communicate with SetGmon (contact Crowcon for wiring details). Each control rack is uniquely identified to the SetGmon software by its address (0-255).

Where one control rack is connected the default address is 0.

To configure and test communications:

- 1 Select '**Link**' from the SetGmon tool bar

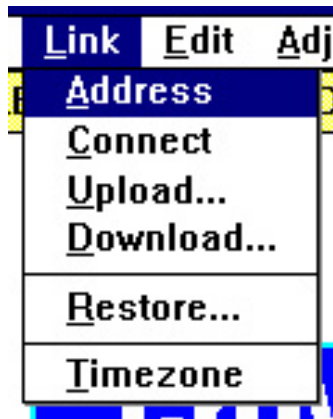

- 2 Select '**A**ddress' from the drop down menu

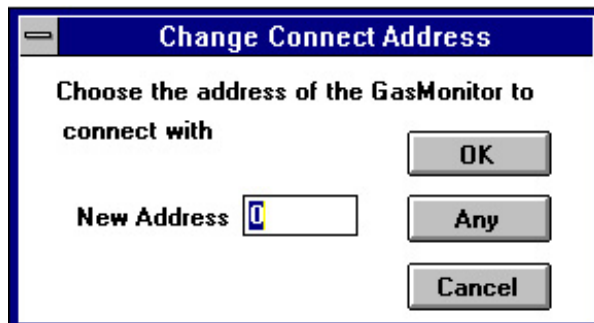

- 3 Enter the address of the Gasmonitor+ control rack to talk to (e.g. '0' for a single rack) and press '**OK**'
- 4 Select '**L**ink' and then '**C**onnect' from the drop down menu and the following display appears.

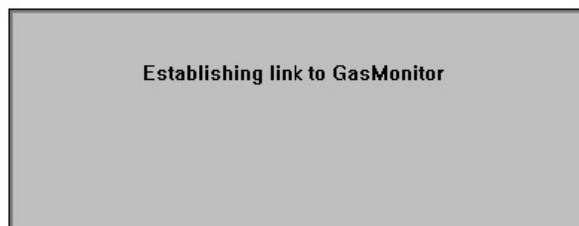

- 5 If connection to the Gasmonitor+ control rack is successful the following screen will appear.

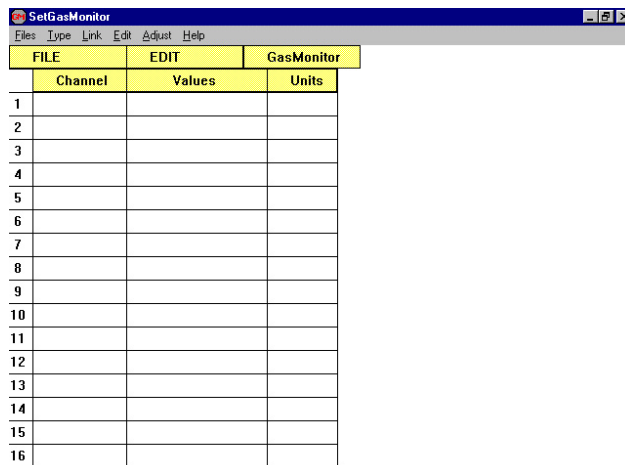

FILE	EDIT	GasMonitor
Channel	Values	Units
1		
2		
3		
4		
5		
6		
7		
8		
9		
10		
11		
12		
13		
14		
15		
16		

- 6 If for any reason communications can not be established an error box will appear, for example:



- 7 Should an error box appear, check the cable is connected securely, the correct COM port is being used or that the COM port is not already in use by another program. If necessary use another COM port.

Configuration Files

General

Each Gasmonitor+ system is supplied fully configured for those detectors purchased with that system.

The specification sheet for that system details the configuration supplied.

A backup copy of the configuration file is provided on the 3 ½" floppy disc which also holds the PC software. Crowcon recommend that this backup copy be updated whenever the system configuration is changed.

Should the Display Module ever need to be changed then this backup copy may be required.

When configuration files are opened and then transferred to/from the Gasmonitor+ control rack the background colour behind the title 'FILE', 'EDIT' and 'Gasmonitor+' change. The difference in colour signifies a difference in the configuration held by the computer and/or Gasmonitor+. When all editing is complete and files have been saved correctly all background colours will be the same. At this time the user may close the application knowing that all files have been updated to the same level.

To create a new configuration file select 'Files' from the SetGmon toolbar and press 'New' on the drop down menu. Press 'OK' on the pop up warning box to start editing the configuration as required.

'Upload...' Configuration From Gasmonitor+

- 1 Establish communications as detailed earlier.
- 2 Select 'Link' from the SetGmon toolbar

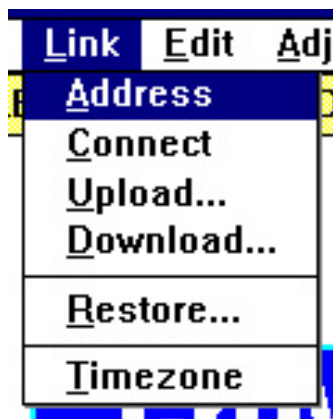

- 3 Select 'Upload...' from the drop down menu. The following display appears.



- After a short delay the following screen will appear. If, instead, an error box appears, check the cable is connected securely, the correct COM port is being used or that the COM port is not already in use by another program. If necessary use another COM port.

FILE	EDIT	GasMonitor	
Channel	Values	Units	
1	SO2	0.00	ppm
2	NO	0.00	ppm
3	HCL	0.00	ppm
4	NH3	0.00	ppm
5	CO	0.00	ppm
6	CH4	0.00	lel
7	CH4	0.00	lel
8	CH4	0.00	lel
9	CH4	0.00	lel
10	CH4	0.00	lel
11	CH4	0.00	lel
12	CH4	0.00	lel
13	CH4	0.00	lel
14	CH4	0.00	lel
15	CH4	0.00	lel
16	CH4	0.00	lel

- Those channels not fitted with input cards are greyed out.

‘Open...’ Configuration From Disc

- To open a configuration file from disc select **‘Files’** from the SetGmon toolbar and then **‘Open’**, the following display will appear.

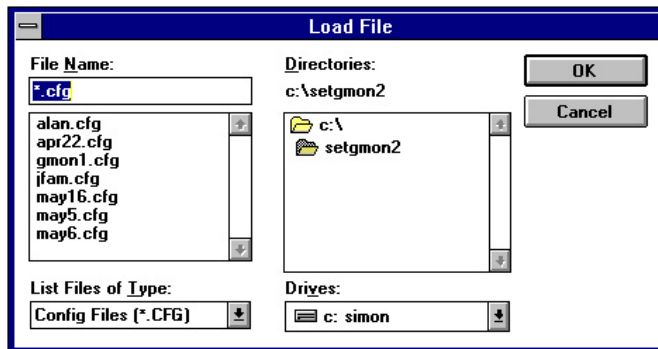

- Select the configuration file to open and press **‘OK’**. A screen similar to that shown below will appear.

SetGasMonitor Editing - UPLOAD			
Files Link Edit Adjust Help			
FILE	EDIT	GasMonitor	
	Channel	Values	Units
1	SO2	0.00	ppm
2	NO	0.00	ppm
3	HCL	0.00	ppm
4	NH3	0.00	ppm
5	CO	0.00	ppm
6	CH4	0.00	lel
7	CH4	0.00	lel
8	CH4	0.00	lel
9	CH4	0.00	lel
10	CH4	0.00	lel
11	CH4	0.00	lel
12	CH4	0.00	lel
13	CH4	0.00	lel
14	CH4	0.00	lel
15	CH4	0.00	lel
16	CH4	0.00	lel

Download... Configuration to Gasmonitor+

- 1 To download a new configuration to a Gasmonitor+ select **Link** from the SetGmon toolbar and then **Download...** to send the new configuration to the Gasmonitor+ control rack. The following display will appear.

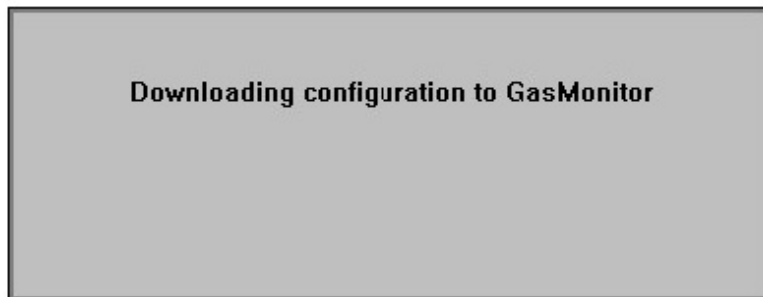

- 2 After approximately 15 seconds the following confirmation screen will appear. Press **OK** to continue.



- 3 If, instead, an error box appears check the cable is connected securely, the correct COM port is being used or that the COM port is not already in use by another program. If necessary use another COM port.

'Save As...' Configuration to Disc

- 1 To save the configuration to disc select '**F**iles' from the SetGmon toolbar and then '**S**ave As' from the drop down menu. The following display appears.

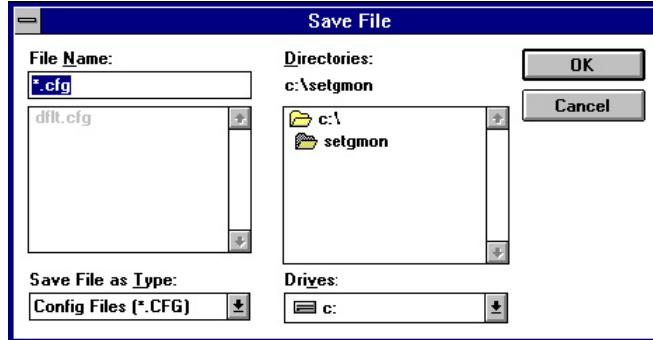

- 2 Type a new file name in the 'File Name' box and press '**O**K' to save the modified file.

Editing Configuration Files

Open the configuration file from disc or upload the configuration from a Gasmonitor+ to be edited.

Select 'Edit' from the SetGmon toolbar and the following screen will appear.

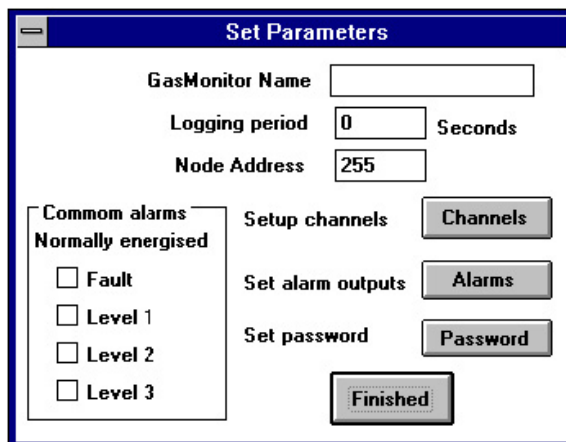

Once the configuration has been edited remember to download the configuration to the Gasmonitor+ control rack and save the configuration on the back up disc.

'Set Parameters' Menu (Common System Settings)

The following table summarises the parameters that may be set from this screen.

Parameter	Function	Comment
Gasmonitor+ Name	Eight characters (letters or numbers) which appear on the Display Module LCD display.	Usually set to the rack serial number.
Logging period	Defines the interval between samples in seconds. Entry must be between 5 and 32000. Up to 1600 readings per channel are stored before being overwritten on a first in first out basis.	Changing the logging period automatically clears the log. Even if data logging is not being used a value must be entered, usually set to 60.
Node Address	Used to set the rack address and allow multiple racks (0-255) to be connected to one PC.	The default value is 0 and should not be changed if only one control rack is connected.
Common Alarms	Checking the box adjacent to the relay description sets that relay to be normally energised in normal operation.	As default the common fault alarm is set as normally energised with other alarms as de-energised.
Setup channels	Pressing this button opens the 'Edit Channels' menu.	See later section for details.
Set alarm outputs	Pressing this button opens the 'Edit Relay Voting Logic' menu.	See later section for details.
Set password	Pressing this button opens the 'Set Password' menu.	See later section for details.

To close the 'Set Parameters' menu press **'Finished'**.

'Edit Channels' Menu (Individual Channel Settings)

- 1 To edit individual channel settings select '**E**dit' from the SetGmon toolbar and then press the '**C**hannels' button. The following screen will appear.

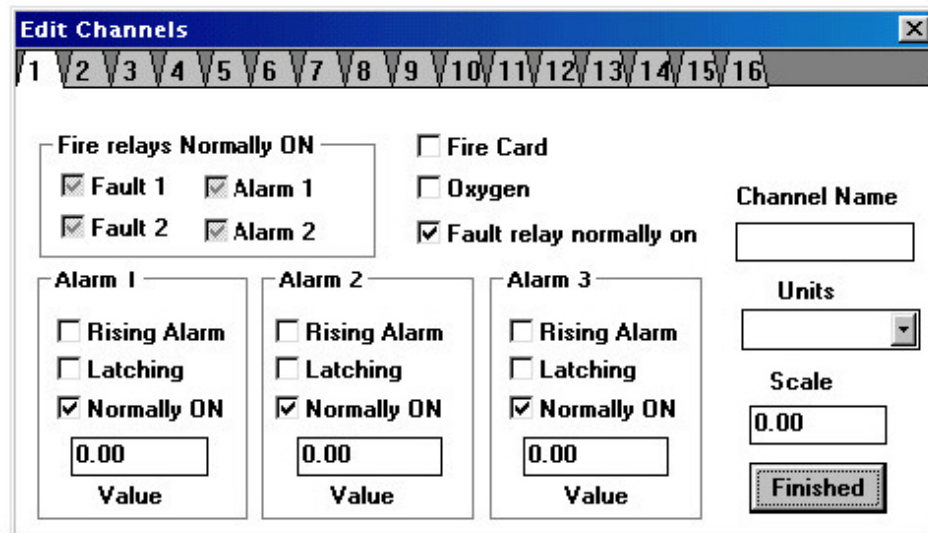

- 2 Pressing any of the numbered tabs (1 to 16) at the top of the pop up screen allows that specific channel to be configured.
- 3 Greyed out boxes represent options which are not available for the type of card selected.
- 4 The software defaults to the input card being configured as a flammable or toxic gas input card. If the input card is connected to an oxygen detector or is a fire card the relevant check box must be selected.
- 5 Channel settings may be copied from one channel to another as follows:
 - Select the channel tab to be copied by clicking the left hand mouse button over the tab.
 - Press the left hand mouse button again over the tab. This stores the channel information.
 - Select the channel that the information is to be copied to by clicking the left mouse button over the tab.
 - To copy the information right click the mouse button over the tab of the channel to be copied to.
- 6 The following table summarises the parameters for each channel that may be set from this screen.

Parameter	Function	Comment
Fire Card	Declares input card type as a Twin Zone Fire Card	
Oxygen	Declares detector type fitted to Universal Gas Input Card as an oxygen detector.	Special indication required as bar graph on input card is driven differently when detecting oxygen.
Fault relay normally on	Sets Universal Gas Input Card fault alarm relay (if fitted) to be set normally energised.	Default setting is normally energised.
Fire relays normally on	If the Fire Card box is checked then individual fire alarm and fault alarm relays connected to the Twin Zone Fire Card can be configured to be normally energised by checking these boxes.	As standard fire alarm relays are normally de-energised and fault alarm relays are normally energised.
Channel Name	3 characters which appear on Display Module LCD when the channel is selected.	Usually set to describe the type of detector fitted to that channel.
Units	Sets the measuring units of the detector fitted to that channel, for example, ppm or LEL.	Units selected are shown on Display Module LCD when channel is selected.
Scale	Sets the full scale range for the detector fitted.	E.g. Oxygen is normally set to 25%vv.
Alarm 1 (2 or 3) Value	Sets the alarm trip point.	The lowest alarm set point

Parameter	Function	Comment
	Entered as a numerical value in the range 0 to 'Scale'.	should be no less than 10% of the 'Scale'
Alarm 1 (2 or 3) Rising Alarm	When checked the alarm relay will operate as the gas concentration rises through the alarm.	When left unchecked this is used primarily for oxygen deficiency alarms.
Alarm 1 (2 or 3) Latching	Checking the 'Latching' box causes the associated relay to activate on alarm and remain active until the gas level has fallen below the alarm value setting AND then RESET is pressed.	Leaving the box unchecked causes the relay to be non-latching i.e. auto-resetting. The default setting is latching.
Alarm 1 (2 or 3) Normally On	Checking this box sets the associated relay as normally energised, de-energising on alarm.	The default setting is normally de-energised.

7 Pressing '**Finished**' returns you to the 'Set Parameters' menu.

'Edit Relay Voting Logic' Menu (Voted Relays)

- 1 To edit the configuration of the Voted Relays select '**Edit**' from the SetGmon toolbar and then press the '**Alarms**' button. The following screen will appear.

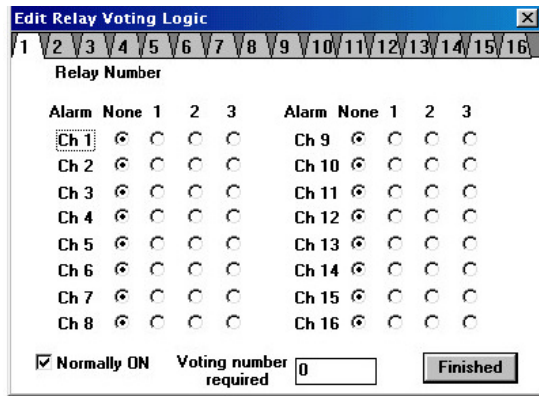

- 2 Up to 16 Voted Relays can be controlled by the Display Module (see page 19). The numbered tabs (1 to 16) represent the relays.
- 3 Various channel alarms may be grouped together to drive the Voted Relay output. For example, selecting ‘Ch 1, Alarm 1’ and ‘Ch 2, Alarm 1’ and placing the number ‘1’ in the ‘Voting number required’ box causes the associated relay to trip if either channel 1 or 2 goes into a level 1 alarm.
- 4 If the number ‘2’ is placed in the ‘Voting number required’ box, then both channels 1 and 2 would have to be in level 1 alarm before the associated relay would trip.
- 5 Checking the ‘Normally ON’ box causes the associated relay output to be normally energised, de-energising on alarm.
- 6 Pressing ‘Finished’ returns you to the ‘Set Parameters’ menu.

‘Set Password’ Menu

- 1 To change the Display Module password select ‘Edit’ from the SetGmon toolbar and then press the ‘Password’ button. The following screen appears.

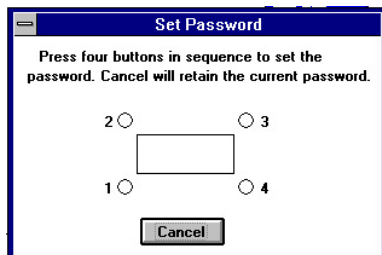

- 2 The screen represents the Display Module LCD display and associated pushbuttons.
- 3 To set the new password click the left mouse button over the numbers 1 to 4 in any sequence of up to 4 presses.

- The screen will automatically disappear and return the user to the ‘Set Parameters’ menu.

Making System Adjustments via SetGmon

Online system adjustments other than configuration changes can be made using the SetGmon software.

Once communications is established upload the configuration from the Gasmonitor+ control rack and select ‘Adjust’ from the SetGmon toolbar to display the following drop down menu.

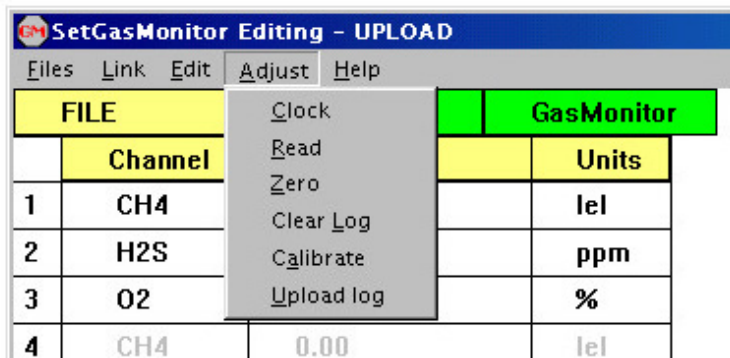

The following table summarises the operation of each function.

Function	Description	Comment
Clock	Sets the internal clock of Gasmonitor+ to the same setting as the PC connected to it.	Ensure time and date on PC is correct before use. Also see ‘Timezone’ function.
Read	Reads current gas levels from the Gasmonitor+ and displays data in the values column of the SetGmon general screen.	

<p>Zero</p>	<p>Allows any one or multiple channels to be zeroed from the PC. Once selected a 'Zero Channel' dialog box appears. Select those channels to be zeroed, ensure detector output corresponds to zero gas and press 'OK'.</p>	<p>If any channel to be zeroed is used with an oxygen detector a prompt to disconnect the oxygen sensor at the detector will appear. This is only necessary with TXgard IS or TXgard D type gas detectors.</p>
<p>Clear Log</p>	<p>Used to clear the Gasmonitor+s memory of any logged data.</p>	
<p>Calibrate</p>	<p>Allows individual input channels to be calibrated. Once selected a 'Calibrate Channel' dialog box appears. Select the channel to be calibrated, ensure calibration gas is applied to that channel, and enter the 'Calibration gas value'. Press 'OK' to calibrate the channel.</p>	<p>Ensure that the detector output has stabilised before calibrating the input card. Detectors with built in amplifiers should be calibrated before the input card.</p>
<p>Upload Log</p>	<p>Transfers logged data from Gasmonitor+ to the PC. Upon selecting 'Upload Log' a 'Save File' dialog box appears. Select the file location and name to save the logged data with a '.log' file extension.</p>	<p>It is important to 'Upload' the Gasmonitor+ configuration BEFORE the logged data. LogManager is used to view the data and convert files to other formats as necessary.</p>

Special Functions

Timezone'

'**Timezone'** allows a predefined offset to be applied to the PC clock to allow for geographical time zones.

Select '**Timezone'** from the '**Link'** menu on the SetGmon toolbar to open the 'Time Zone' dialog box.

In the appropriate box enter the time shift in hours and press '**OK**'.

When the '**Clock'** function is now selected from the '**Aadjust'** menu on the SetGmon toolbar the offset will be applied and the Gasmonitor+ clock reset.

Print' Configuration File

To print a configuration file open or upload the configuration and select '**Print'** from the '**Files'** menu on the SetGmon toolbar.

Restore...' Calibration Settings

The '**Restore...'** function is used when replacing a Display module.

The Display Module holds the system configuration data and calibration data for each channel fitted to the system. The calibration data is used to scale readings from the input cards before

displaying the information on the Display Module LCD.

When replacing a Display Module:

Gas test and recalibrate detectors as necessary.

- 1 '**Upload...'** the configuration and calibration data from the Display Module.

- 2 Replace the Display Module as required.
- 3 **‘Download...’** the configuration data to the new Display Module.
- 4 **‘Restore...’** the calibration data.

LogManager Software

Overview

LogManager has three main functions:

- Displaying logged data that has been retrieved from Gasmonitor+.
- Printing logged data.
- Conversion of logged data to. CSV file format.

All functions are carried out using the on screen pop up menus which are discussed in the following sections.

Running LogManager

Select ‘LogManager’ from the ‘Start’ menu. The following screen will appear:

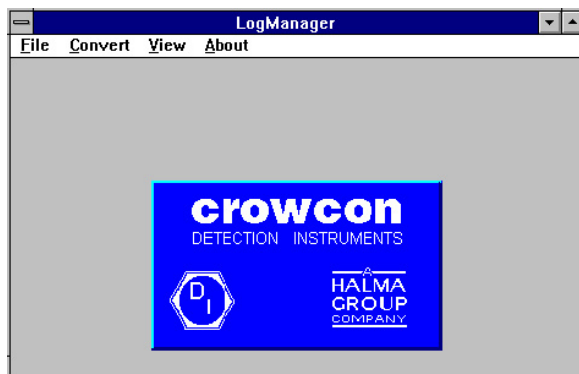

Viewing a Logged File

Select **‘Open Log’** from the **‘Files’** menu on the LogManager toolbar. The following screen will appear.

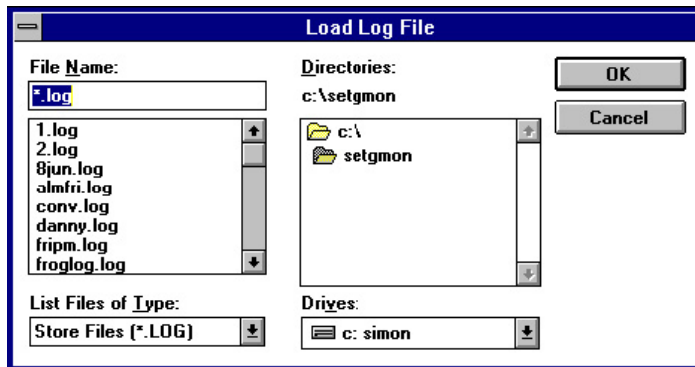

Select the logged file to open and press ‘OK’. The logged data will be shown graphically as follows.

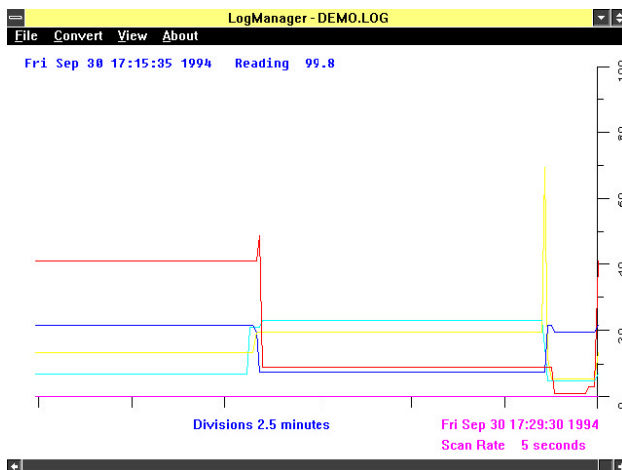

The vertical scale is ranged to display the largest range of the displayed channels.

Select ‘View’ from the LogManager toolbar to turn on or off specific channels.

Moving the cursor over the screen displays the exact time, date and reading at the cursor location.

‘Convert’ing Files to .CSV Format

This function converts the logged data into a comma separated variable file format. This file can then be imported into spreadsheet applications such as Lotus 123 or Microsoft Excel.

Selecting 'Convert' from the LogManager toolbar. The following screen will appear.

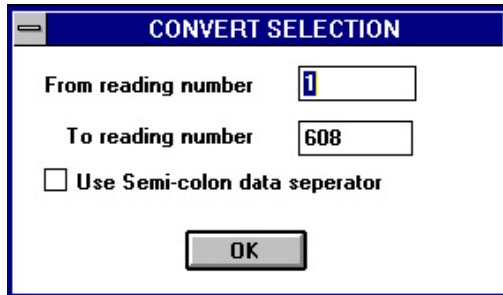

As standard a comma is used to separate variables. In some countries commas are used to represent a decimal place. In this case check the 'Use semicolon data separator'.

As default the 'Convert Selection' menu includes data from the first to the last value recorded. These can be over-typed if required to convert a smaller selection.

Upon pressing 'OK' the logged data is converted and must then be saved.

'Save As' .CSV Files to Disc

Once the logged data has been converted select 'Save As' from the 'File' menu and the following dialog box will appear.

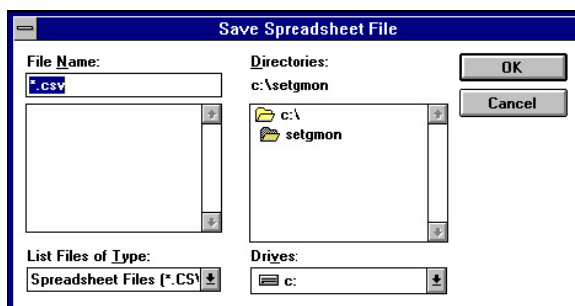

Enter the required filename and destination directory and press 'OK' to save the file in .CSV file format.

‘Print’ing Logged Data

Select **‘Print’** from the **‘File’** menu on the LogManager toolbar to print the logged data in tabular format.

APPENDIX C

SPARE PARTS LIST

Figure 37 shows an exploded view of a typical Gasmonitor+ system. To obtain any spare parts not detailed please contact Crowcon directly.

Part Number	Description	Comments
M05732	Blank Channel label	
S01699	Motherboard	
C01316	PC software & 9 way interface lead	
C01327	9 way interface lead	
M02186	RFI screening plate kit	
E01006	12Vdc, 7Ah sealed lead acid battery	
E01058	500mA fuse – wire ended	
	Calibration gas	Position contact Crowcon
Made to order	Input/output module connecting ribbon A	Recorder outputs. Specify length.
Made to order	Input/output module connecting ribbon B	Detecting heads. Specify length.
Made to order	Input/output module connecting ribbon C	Blank position. Specify length.
Made to order	Relay module connecting ribbon A	Specify length.
Made to order	Relay module connecting ribbon B	Specify length.

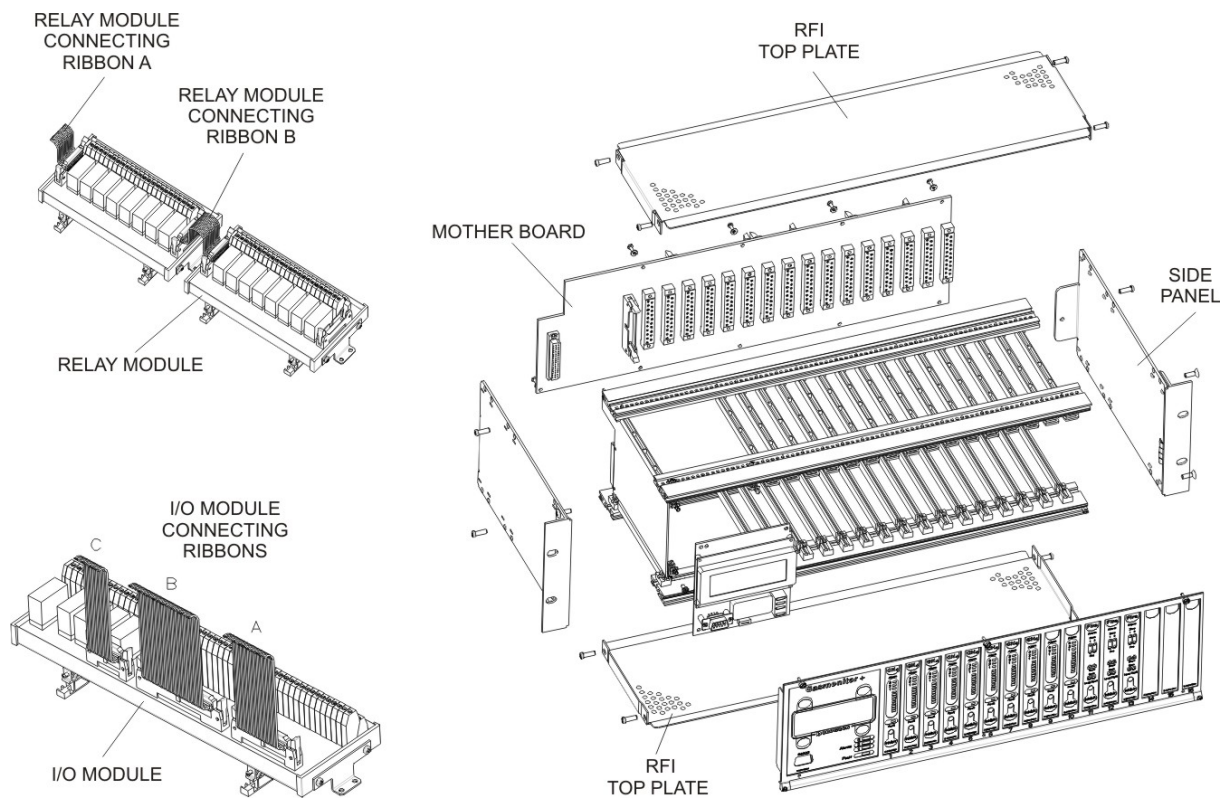

Figure 37: Gasmonitor+ Exploded View

WARRANTY

This equipment leaves our works fully tested and calibrated. If within a period of one year from the date of purchase it is proved to be defective by reason of faulty workmanship or material, we undertake at our option either to repair or replace it free of charge, subject to the conditions below.

- 1 In order for returning goods to be processed efficiently the following steps should be taken before goods are returned.

For warranty returns, contact our customer support team on 01235 557711 to obtain:

- Validation the appropriate action/return of goods
- A goods returns number for the return
- A returns form for identification and tractability purpose
Clearly mark on the returns paperwork the following details:
- Contact name, phone number & fax number
- Description of goods being returned and quantity, including any accessories
- Reason for return

Goods will not be accepted for warranty without a Crowcon returns number. It is essential that the address label supplied be attached to the outer packaging of the returned goods. The guarantee will be rendered invalid if the instrument is found to have been altered, modified, dismantled or tampered with.

- 2 We accept no liability for consequential or indirect loss or damage howsoever arising (including any loss or damage arising out of the use of the instrument) and all liability in respect of any third party is expressly excluded.
- 3 The guarantee does not cover the accuracy of calibration after the system has been put into use. The system must be maintained in accordance with the Installation, Operating and Maintenance Instructions.
- 4 The guarantee does not include the cosmetic finish of the product, and is dependant upon installation and operation of the product in accordance with the procedures set out in the Installation, Operating and Maintenance Instructions.

- 5 Our liability in respect of defective equipment shall be limited to the obligations set out in the guarantee and any further warranty, condition or statement, express or implied statutory or otherwise as to the merchantable quality of our equipment or its fitness for any particular purpose is excluded except as prohibited by statute. This guarantee shall not affect a customer's statutory rights.
- 6 Units that are returned to Crowcon as faulty, and are subsequently found to be fault-free may be subject to a small handling charge to cover inspection and return shipping costs.

A HALMA COMPANY